































3 KALIP ELEMENLARI
DIE COMPONENTS
NORMALIEN





Index

Contents	Page	Contents	Page
 <p>M301-00 Mekanik Dayamalar Gage Einweiser BMW - MERCEDES - BENZ - FCA - FORD - OPEL - VW/AUDI</p>	3.12	 <p>M301-09 Mekanik Dayamalar Gage Einweiser</p>	3.19
 <p>M301-01 Sertleştirilmiş Mekanik Dayamalar Gage Hardened Einweiser Gehärtet BMW - MERCEDES - BENZ - FCA - FORD - OPEL - VW/AUDI</p>	3.13	 <p>M301-10 Mekanik Dayamalar Gage Einweiser MERCEDES - BENZ</p>	3.20
 <p>M301-02 Sertleştirilmiş Kontrol Parçalı Mekanik Dayamalar Gage for Sensor, Hardened Einweiser für Teillagekontrolle Gehärtet</p>	3.14	 <p>M301-11 Sertleştirilmiş Mekanik Dayamalar Gage Hardened Einweiser Gehärtet MERCEDES - BENZ</p>	3.21
 <p>M301-03 Mekanik Dayamalar için Sensör ve Konnektörler Sensor and Connector Sensoren und Steckverbindungen</p>	3.15	 <p>M301-12 Sertleştirilmiş Hassas Mekanik Dayamalar Precision Gage Hardened Feinweiser Gehärtet VW/AUDI</p>	3.22
 <p>M301-04 Kontrol Parçalı Mekanik Dayamalar Gage for Sensor Lagekontrolle für Platinen VW/AUDI</p>	3.16	 <p>M301-13 Sertleştirilmiş Mekanik Dayamalar Gage Hardened Einweiser Gehärtet BMW - MERCEDES - BENZ</p>	3.23
 <p>M301-05 Sertleştirilmiş Kontrol Parçalı Mekanik Dayamalar Gage for Sensor, Hardened Einweiser für Teillagekontrolle Gehärtet BMW - FCA</p>	3.17	 <p>M301-14 Mekanik Dayamalar Gage Einweiser</p>	3.24
 <p>M301-06 Kontrol Parçalı Mekanik Dayamalar Front Gage Einweiser für Teillagekontrolle Gehärtet FCA - OPEL</p>	3.18	 <p>M301-15 Kontrol Parçalı Dayama Position Control for Blanks Lagekontrolle für Platinen VW/AUDI</p>	3.25















Index

Contents	Page	Contents	Page
 <p>M301-16 Mekanik Dayamalar Gage Einweiser</p>	3.26	 <p>M303-02 Merkezleme Pimleri Locating Pins Zentrierbolzen BMW - VW/AUDI</p>	3.32
 <p>M301-17 Mekanik Dayamalar Gage Einweiser</p>	3.27	 <p>M304-01 Hava Pimleri Air Pins Duruckbolzen BMW - FORD - OPEL</p>	3.33
 <p>M302-01 Konik Merkezleme Üniteleri Locating Cone Zentriereinheiten mit Abstimscheiben FCA - VW/AUDI</p>	3.28	 <p>M304-07 Hava Pimleri Air Pins Unterluftbolzen VW/AUDI</p>	3.34
 <p>M302-02 Konik Merkezleme Üniteleri Locating Cone Zentriereinheiten mit Abstimscheiben FCA - VW/AUDI</p>	3.29	 <p>M304-08 Hava Pimleri Air Pins Unterluftbolzen BMW - MERCEDES - BENZ - VDI 3002</p>	3.35
 <p>M302-03 Ayar Plakaları Shim Plates Abstimscheibe</p>	3.30	 <p>M304-09 Hava Pimleri Air Pins Unterluftbolzen VW/AUDI - VDI 3002</p>	3.36
 <p>M302-08 Konik Merkezleme Üniteleri Locating Cones Zentriereinheiten mit Abstimscheiben</p>	3.31	 <p>M304-10 Hava Pimleri Air Pins Unterluftbolzen VW/AUDI</p>	3.37
 <p>M303-01 Merkezleme Pimleri Locating Pins Zentrierbolzen FCA</p>	3.32	 <p>M305-04 Çıkarıcı Set, Gazlı Yay, Kovan ve Bronz Grafitli Burç Lifters with Gas Springs Sleeve and Bushes, Self-lubricating Federbolzen</p>	3.38















Index

Contents	Page	Contents	Page
 <p>M305-05 Flaş Kaldırıcı Flange Lifter Kantenheber</p>	3.39	 <p>M307-01 Frenleyiciler Retainer Bolts Zugbolzensatz FCA - FORD</p>	3.46
 <p>M305-06 Flaş Kaldırıcı Flange Lifter Kantenheber</p>	3.40	 <p>M308-01 Akışkan Yönlendirici Flux Control Verteilerblock</p>	3.47
 <p>M305-07 Flaş Kaldırıcı Flange Lifter Kantenheber FCA</p>	3.41	 <p>M308-07 Hava Birleştirme Braketleri Air Coupling Brackets Luftanschlussbock</p>	3.48
 <p>M305-08 Flaş Kaldırıcı Flange Lifter Kantenheber FCA</p>	3.42	 <p>M309-02 Kızak Stoplama Bloğu Slide Stop Block Schieberanschlag FCA</p>	3.49
 <p>M305-09 Universal Çıkarıcı Ünitesi Universal Lifter Unit Universelle Hochhebereinheit BMW</p>	3.43	 <p>M309-04 Kızak Stoplama Bloğu Slide Stop Block Schieberanschlag VW/AUDI</p>	3.50
 <p>M306-02 Emniyet Pimleri Pad Retainer Pins Steckbolzen VW/AUDI - VDI 3365</p>	3.44	 <p>M309-05 Kızak Stoplama Bloğu Slide Stop Block Schieberanschlag BMW - VW/AUDI</p>	3.51
 <p>M306-03 Emniyet Pimleri Pad Retainer Pins Steckbolzen VW/AUDI - VDI 3365</p>	3.45	 <p>M309-06 Kızak Stoplama Bloğu Slide Stop Block Schieberanschlag BMW - VW/AUDI</p>	3.52















Index

Contents	Page	Contents	Page
 <p>M309-07 Kam Stoper Slider Stop Damping System Dämpfungssystem Schieberanschlag VW/AUDI</p>	3.53	 <p>M310-08 Makara Roller Rolle VW/AUDI</p>	3.63
 <p>M309-08 Kızak Stoplama Bloğu Slide Stop Block Schieberranschlag</p>	3.54	 <p>M310-08 Makaralı Sürücü Üniteler Roller Group Förderrolle FCA</p>	3.64
 <p>M310-01 Makaralı Kollu Kaldırıcılar Roller Stock Lifter Federnde Laufrolle VW/AUDI</p>	3.55 - 3.60	 <p>M310-09 Destek Kolu Coil Support Abstreifer</p>	3.65
 <p>M310-03 Makaralı Sürücü Üniteler Roller Group Förderrolle FIAT</p>	3.61	 <p>M310-10 Makaralı Sürücü Ünite Roller Drive Unit Rollenantriebseinheit</p>	3.66
 <p>M310-04 Bilyalı Taşıyıcılar Ball Carriers Kugelrollensystem FCA</p>	3.61	 <p>M311-01 Elastomer Yaylar için Sabitleme Pimleri Pin for Elastomer Springs Aufnahmebolzen FCA</p>	3.67
 <p>M310-05 Çelik Makaralar Steel Roller Stahlrolle VW/AUDI</p>	3.62	 <p>M311-05 Elastomer Yaylar için Sabitleme Pimleri Pin for Elastomer Springs Führungsbolzen DIN 9835</p>	3.68
 <p>M310-06 Plastik Makaralar Plastic Roller Plastikrolle</p>	3.62	 <p>M312-03 Emniyet Cıvata ve Rondela Setleri Retainer Bolt Sets Zugbolzensatz FORD</p>	3.69















Index

Contents	Page	Contents	Page
 <p>M312-08 Emniyet Cıvata ve Rondela Setleri Retainer Bolt Sets Zugbolzensatz</p>	3.70	 <p>M316-02 Kavrama Somunları Coupling Nuts Kupplungsmutter FCA</p>	3.77
 <p>M313-01 Emniyet Setleri için Borular Spacer Tubes Distanzbuchse</p>	3.71	 <p>M317-04 Kama Key Passfeder FCA</p>	3.78
 <p>M313-02 Emniyet Setleri için Borular Spacer Tubes Distanzbuchse BMW</p>	3.72	 <p>M317-05 Kama Key Passfeder VW/AUDI</p>	3.79
 <p>M313-04 Elastomer Yaylar için Rondela Washer for Elastomer Spring Federscheibe</p>	3.73	 <p>M317-07 Kama Key Passfeder FORD</p>	3.80
 <p>M313-05 Rondela Washer Unterlegscheibe</p>	3.74	 <p>M317-08 Kama Key Passfeder FCA</p>	3.81
 <p>M313-06 Rondela Washer Unterlegscheibe</p>	3.75	 <p>M317-10 Kama Key Passfeder</p>	3.82
 <p>M316-01 Kavrama Plakaları Coupling Plates Befestigungsplatte FORD</p>	3.76	 <p>M317-11 Kama Key Passfeder</p>	3.83













Index

Contents	Page	Contents	Page
 <p>M317-12 Konumlandırma Bloğu Locating Block Fangbacke VW/AUDI</p>	3.84	 <p>M318-08 Boşluk Ayar Plakası Shim Unterlegscheibe</p>	3.93
 <p>M317-16 Kama Key Passfeder VW/AUDI</p>	3.85	 <p>M318-09 Baskı Plakası Pressure Plate Druckplatte</p>	3.94
 <p>M317-17 Kama Key Passfeder VW/AUDI</p>	3.85	 <p>M319-01 Sabitleme Kelepçeleri Coupling Clamps Befestigungselement FCA</p>	3.95
 <p>M318-03 Stoplama Blokları Balance Blocks Distanzstück VW/AUDI</p>	3.86 - 3.87	 <p>M319-01 Bilyalı Yatak Sleeve Führungseinheit FCA</p>	3.95
 <p>M318-05 Stoplama Blokları Balance Blocks Distanzstück VW/AUDI</p>	3.88 - 3.89	 <p>M319-02 Dişli Ayar Plakaları Spacer Plates, Toothed with Adjusting Plate Distanzplatte Gezahnt BMW - FCA - VW/AUDI</p>	3.96
 <p>M318-06 Stoplama Blokları Balance Blocks Distanzstück VW/AUDI</p>	3.90 - 3.91	 <p>M320-03 Kam Hareket Mesafesi Ayar Plakaları Cam Pad Guide Wear Plates Führung für Ziehkissen</p>	3.97
 <p>M318-07 Silindirik Stoplama Bloğu Cylindrical Stop Block Abstandsblock FCA</p>	3.92	 <p>M320-07 Zorunlu Dönüş Destek Plakaları Positive Return Plates, Steel Zwangsrückholer FCA</p>	3.98











Index

Contents	Page	Contents	Page
 <p>M321-01 Boşluk Ayarı için Profil Spacing Bar Abstellbolzen VW/AUDI</p>	3.99 - 3.100	 <p>M322-01 Şapkalı Şerit Pimi, Yay-yüklemeli Strip Guiding Pin with Collar, Spring-loaded Streifenführung mit Bund, Gefedert</p>	3.107 - 3.108
 <p>M321-02 Montajlı Profil Gövde Pipe with Assembly Klapprohrkörper mit Baugruppe VW/AUDI</p>	3.101	 <p>M322-02 Dişli Tapa Screw Plug Verschlusschraube</p>	3.108
 <p>M321-03 Montajlı Profil Gövde Pipe with Assembly Klapprohrkörper mit Baugruppe VW/AUDI</p>	3.102	 <p>M323-01 Pilot Pim Ünitesi Pilot Unit Suchereinheit MERCEDES-BENZ</p>	3.109
 <p>M321-04 Profil 5x50x70-L480 Laser Cutting Part Rohrlaserteil VW/AUDI</p>	3.103	 <p>S510-02 Emniyet Pimleri için Amortisör Vulkolonlar Shock Absorber for Pad Retainer Pins Halteelement OPEL</p>	3.110
 <p>M321-04 Profil 3x50x70-L480 Laser Cutting Part Rohrlaserteil VW/AUDI</p>	3.104	 <p>S511-01 Elastomer Tıpa Elastomer Cap Elastomerdruckstück FCA - PSA</p>	3.111
 <p>M321-05 Genişlik Ayar Profili Set 5 mm Pipe Box Set 5 mm DIY-Klapprohr-Box 5 mm VW/AUDI</p>	3.105	 <p>S515-03 Elastomer Sıyrıcılar Stripper for Blanking Dies Abstreifer für Platinenschnitte FCA - VW/AUDI</p>	3.112
 <p>M321-05 Genişlik Ayar Profili Set 3 mm Pipe Box Set 3 mm DIY-Klapprohr-Box 3 mm VW/AUDI</p>	3.106	 <p>Z401-01 Zimba Tutucu Stamp Retainer Halteplatte FCA - PSA - RENAULT</p>	3.113

Index

Contents	Page	Contents	Page
 <p>Z401-02 Altlık Plakası Backing Plate Druckplatte FCA - PSA - RENAULT</p>	3.114	 <p>M314-01 Yaylı Iticiler Spring Plungers Federnde Druckstücke mit Sechskant</p>	3.120
 <p>Z401-06 Zimba Stamp Buchstabenstempel FCA - PSA - RENAULT</p>	3.115	 <p>M314-02 Yaylı Iticiler Spring Plungers Federnde Druckstücke mit Sechskant</p>	3.120
 <p>Z401-07 Zimba Stamp Buchstabenstempel FCA - PSA - RENAULT</p>	3.116	 <p>M314-03 Yaylı Iticiler Spring Plungers Federnde Druckstücke mit Sechskant FCA</p>	3.121
 <p>Z402-03 Konumlandırma Zimbası Visual Locator Punch Endkontrolstempel VW/AUDI</p>	3.117	 <p>M314-04 Yaylı Iticiler Spring Plungers Federnde Druckstücke mit Sechskant</p>	3.122
 <p>Z000166439 Kabartmalı Çapak Kaydırma Plakası Stainless Steel Embossed Sheet Geprägt Scheiße</p>	3.118	 <p>M314-05 Yaylı Iticiler için Ayar Takımı Insertion Tool for Spring Plungers Beschreibung</p>	3.123
 <p>A101-15 Rondela Washer Scheibe</p>	3.118	 <p>M315-01 Stoplama Civataları Shoulder Screws Schulter-Passschrauben</p>	3.124
 <p>M307-04 Tespit Civataları Retainer Bolts Haltebolzen</p>	3.119	 <p>M315-02 Tespit Civataları Retainer Bolts Haltebolzen</p>	3.125

Index

Contents	Page	Contents	Page
 <p>S504-03 Yaylı İtçiler Spring Plungers Federnde Druckstücke mit Sechskant VDI 3004</p>	3.126	 <p>S512-1XX Delikli Vulkolon Yaylar Elastomer Springs, Hollow Elastomerfeder</p>	3.132
 <p>S504-04 Yaylı İtçiler Spring Plungers Federnde Druckstücke mit Sechskant VDI 3004</p>	3.127	 <p>S513-1XX Vulkolon Yaylar Elastomer Springs Elastomerfeder</p>	3.132
 <p>S504-05 Yaylı İtçiler Spring Plungers Federnde Druckstücke mit Sechskant VDI 3004</p>	3.128	 <p>S514-XXX Delikli Vulkolon Yaylar Elastomer Springs, Hollow Elastomerfeder FCA - PSA</p>	3.133 - 3.134
 <p>S504-06 Yaylı İtçiler Spring Plungers Federnde Druckstücke mit Sechskant VDI 3004</p>	3.129	 <p>D901-01-745 Kalıp Alıştırma Boyası Dressing Paste for Surface Control Retuschierfarbe</p>	3.135
 <p>S504-07 Yaylı İtçiler Spring Plungers Federnde Druckstücke mit Sechskant VDI 3004</p>	3.130		
 <p>S504-08 Yaylı İtçiler için Ayar Takımı Insertion Tool for Spring Plungers Beschreibung</p>	3.131		
 <p>S510-05 Delikli Vulkolon Yaylar Elastomer Springs, Hollow Elastomerfeder</p>	3.131		

3

 Material :
 CK60
 Forged

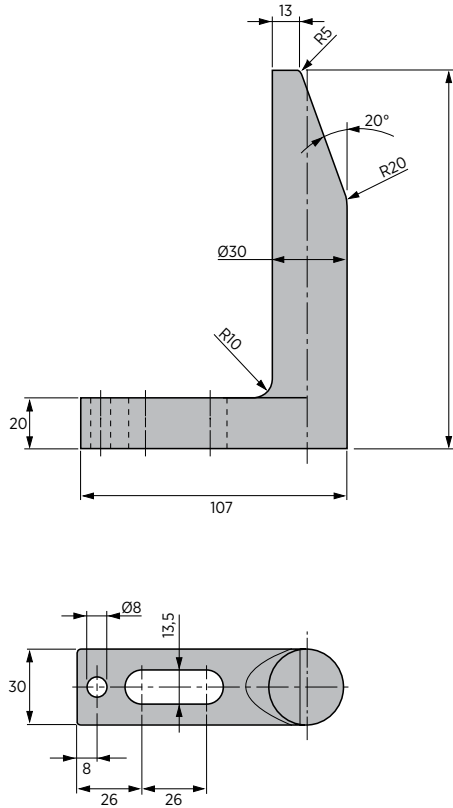
 Different lengths on request;
 Max. Length: 350 mm

CODE	l
M301-00-065	65
M301-00-090	90
M301-00-120	120
M301-00-150	150
M301-00-180	180
M301-00-250	250
M301-00-300	300
M301-00-350	350

Order Example:
 l= 165

Order Code:
 M301-00-165

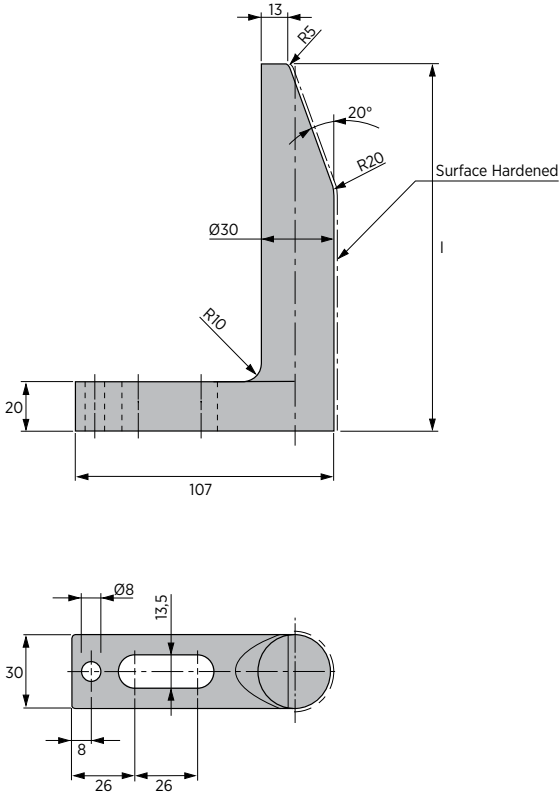
 Material :
 CK60
 Forged

 Hardened
 HRC 56 + 60

 Different lengths on request;
 Max. Length: 350 mm

3

CODE	I
M301-01-065	65
M301-01-090	90
M301-01-120	120
M301-01-150	150
M301-01-180	180
M301-01-250	250
M301-01-300	300
M301-01-350	350

Order Example:
 I= 165

Order Code:
 M301-01-165

3

1 Material :
 CK60
 Forged

 Hardened
 HRC 50 ÷ 55

2 Material:
 Plate
 St37

 Different lengths on request;
 Max. Length: 250 mm

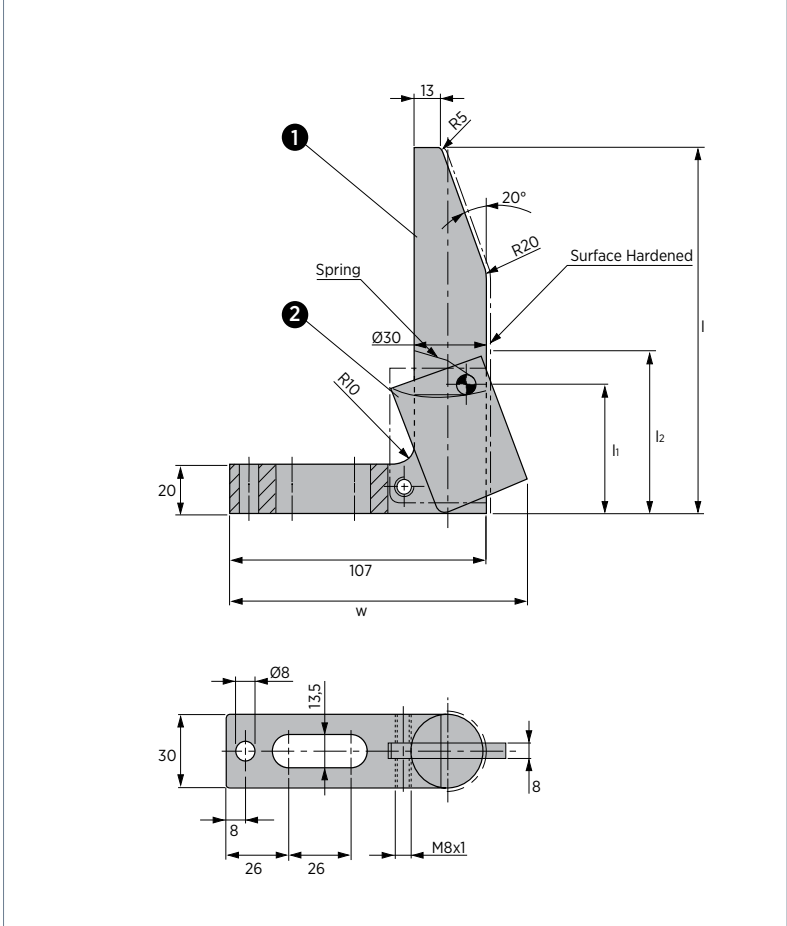

CODE	w	l	h ₁	h ₂
M301-02-120	120	120	55	70
M301-02-150	120	150	55	70
M301-02-180	124	180	105	120
M301-02-250	124	250	105	120
CODE	w	l	h ₁	h ₂
M301-02-I	120	121 ÷ 179	55	70
M301-02-I	124	181 ÷ 249	105	120

Order Example:
 l= 165

Order Code:
 M301-02-165

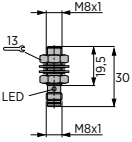
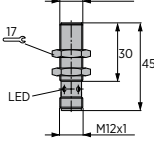
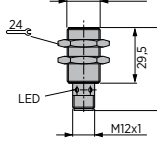
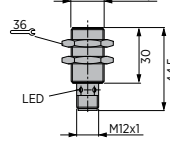
SENSORS
M301-03-01-001

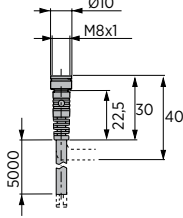
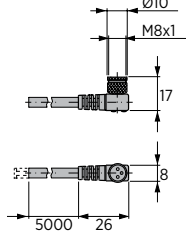
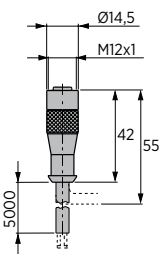
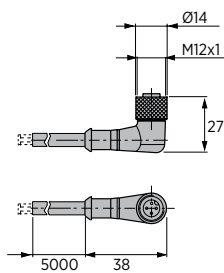
M301-03-01-002

M301-03-01-003

M301-03-01-004

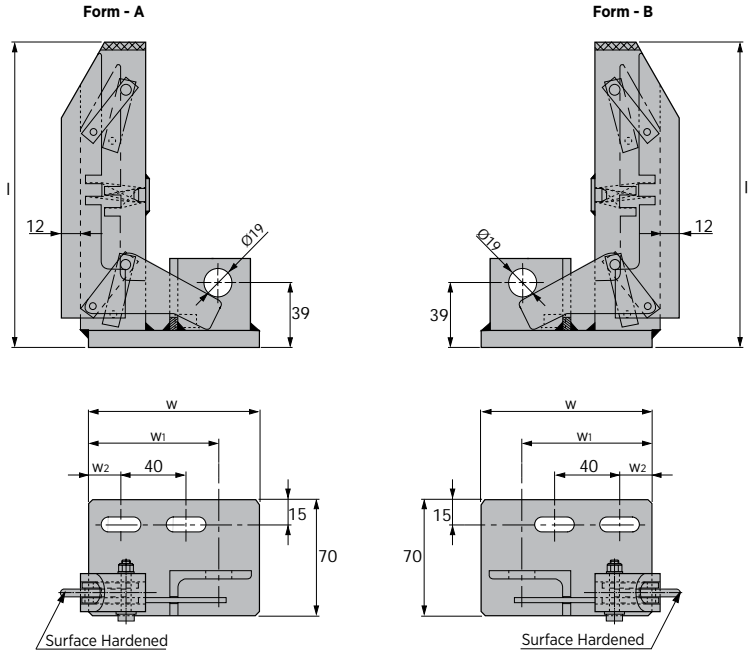
 Manufactured by
BALLUFF

3
CONNECTORS
M301-03-02-001

M301-03-02-002

M301-03-02-003

M301-03-02-004

CODE	M301-03-01-001	M301-03-01-002	M301-03-01-003	M301-03-01-004
Rated operational voltage (Ue)	24 V DC	24 V DC	24 V DC	24 V DC
Supply voltage (Ub)	10...30 V DC	10...30 V DC	10...30 V DC	10...30 V DC
No load supply current (I _{o max.})	≤ 7 mA	≤ 10 mA	≤ 10 mA	≤ 25 mA
Residual current (I _r)	≤ 10 µA	≤ 50 µA	≤ 50 µA	≤ 80 µA
Repeat accuracy (R)	≤ 5 %	≤ 5 %	≤ 5 %	≤ 5 %
Ambient temperature range (T _a)	-40...+85° C	-25...+85° C	-25...+70° C	-25...+70° C
Frequency of operating cycles (f)	5000 Hz	2000 Hz	1000 Hz	150 Hz
Degree of protection per IEC 60529	IP 68	IP 68	IP 67	IP 67
Housing Material	Stainless Steel	Stainless Steel	Brass	Brass
Connection	Connector	Connector	Connector	Connector
Approval	CE/UL	CE/UL	CE/UL	CE/UL

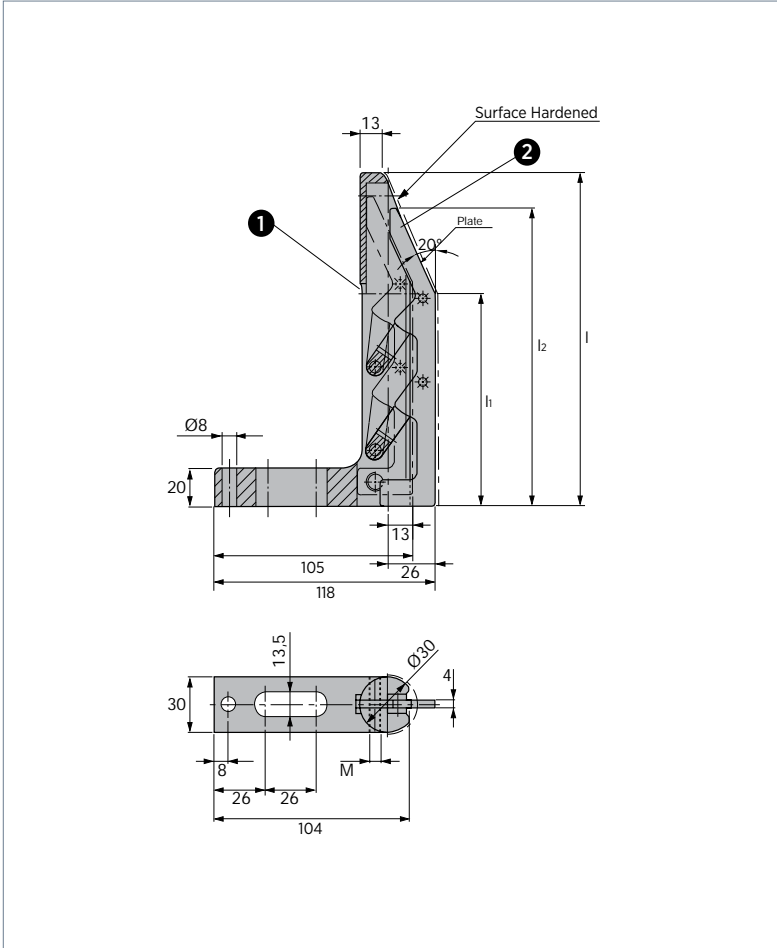
3

 Material :
 Steel
 Hardened
 HRC 60 ± 62

CODE	Form	w	l	w ₁	w ₂
M301-04-0145001	A	105	145	80	25
M301-04-0145002	B	105	145	80	25
M301-04-0145030	A	101	145	76	21
M301-04-0145031	B	101	145	76	21
M301-04-0185003	A	105	185	80	25
M301-04-0185004	B	105	185	80	25
M301-04-0185032	A	101	185	76	21
M301-04-0185033	B	101	185	76	21
M301-04-0225005	A	105	225	80	25
M301-04-0225006	B	105	225	80	25
M301-04-0225034	A	101	225	76	21
M301-04-0225035	B	101	225	76	21



1 Material (Gage) :
CK60
Forged



Hardened
HRC 58 ÷ 60

2 Material (Plate) :
St37

Hardened
HRC 58 ÷ 60

3

CODE	I	h	l ₂	M
M301-05-120	120	78	113	M8x1
M301-05-120-002	120	78	113	M12x1
M301-05-150	150	90	130	M8x1
M301-05-150-002	150	90	130	M12x1
M301-05-180	180	114	160	M8x1
M301-05-180-002	180	114	160	M12x1
M301-05-250	250	114	160	M8x1
M301-05-250-002	250	114	160	M12x1
M301-05-250-003	250	184	230	M8x1
M301-05-250-004	250	184	230	M12x1

3

 Material :
 St37

Sensor not included.

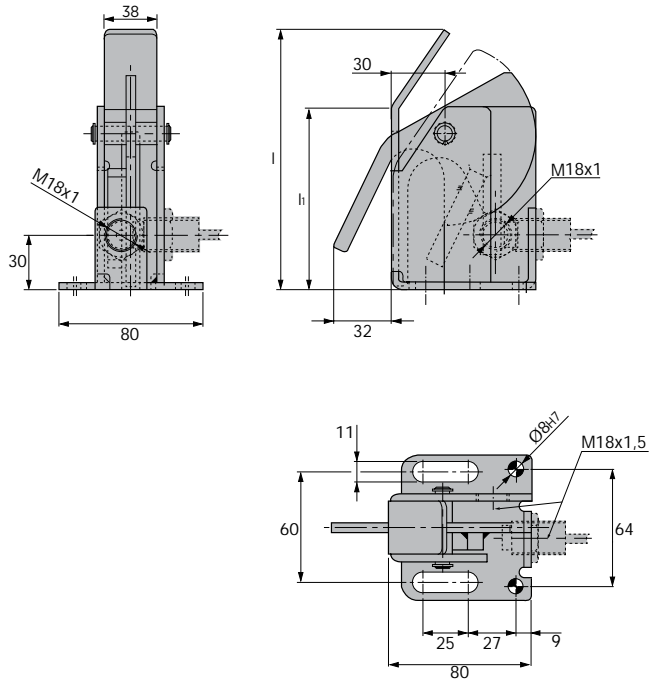

CODE	l	h
M301-06-075-117	117	75
M301-06-100-142	142	100
M301-06-150-192	192	150

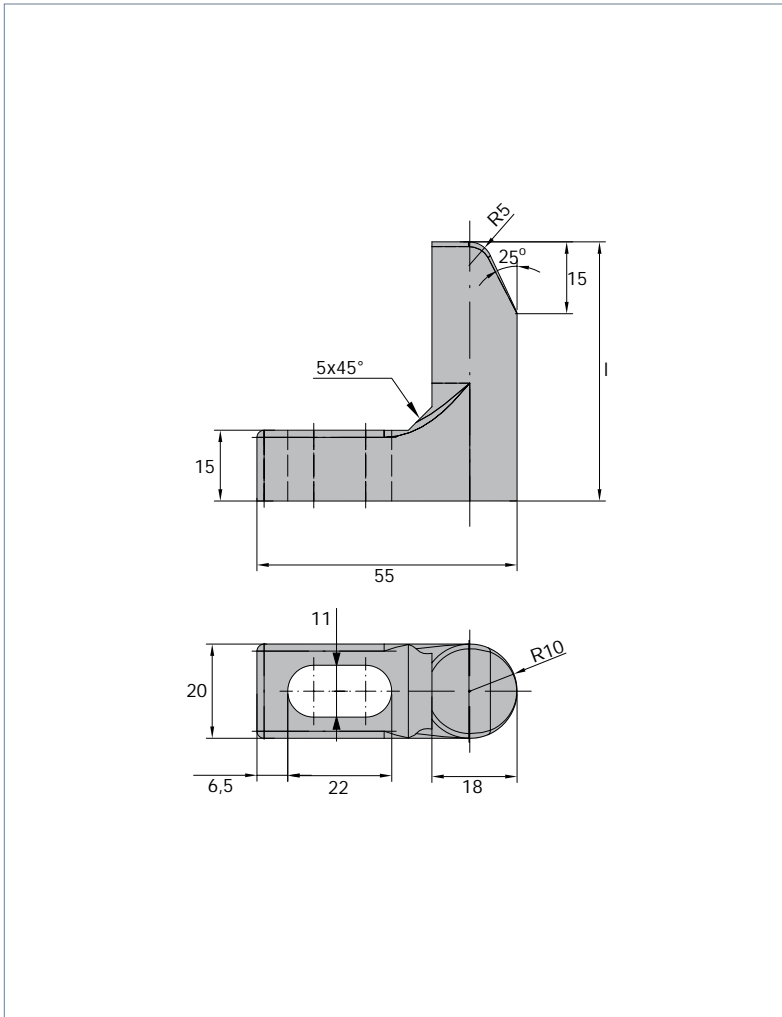
 Material :
 CK45
 Forged

3

CODE	I
M301-09-055	55
M301-09-065	65
M301-09-090	90
M301-09-095	95
M301-09-120	120

Order Example:
 I= 120

Order Code:
 M301-09-120

3



Material :
CK60
Forged

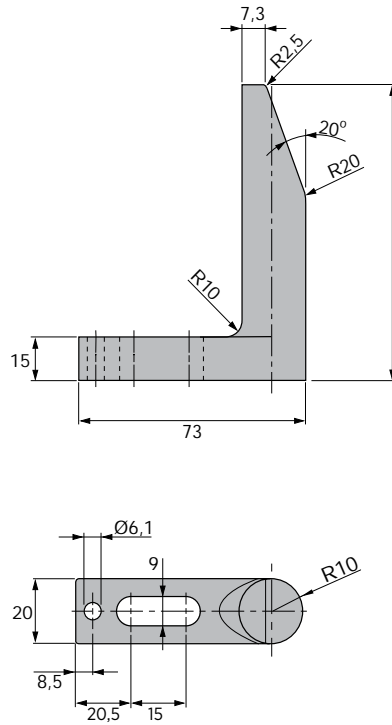

CODE	I
M301-10-065	65
M301-10-090	90

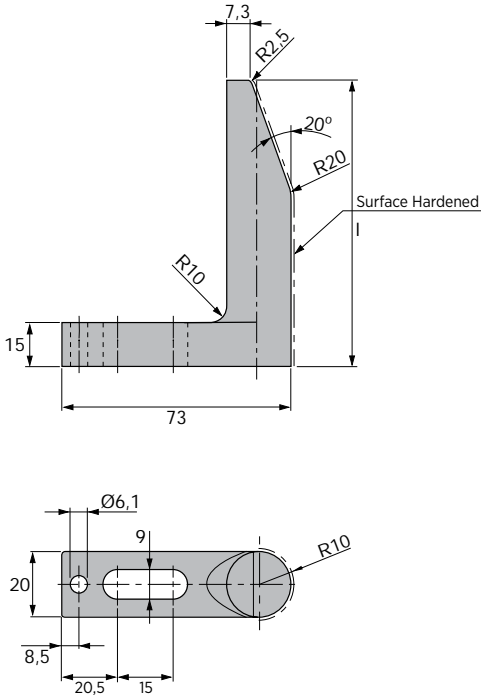
 Material :
 CK60
 Forged

 Hardened
 HRC 58 ÷ 60

3

CODE	I
M301-11-065	65
M301-11-090	90

3

 Material :
 CK60
 Forged

 Hardened
 HRC 58 ÷ 60

Different lengths on request;

Max. Length: 350 mm

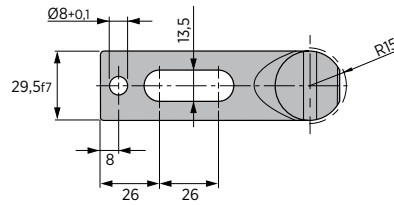
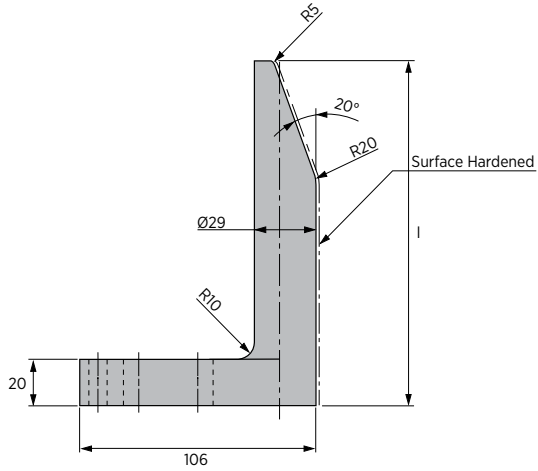

CODE	I
M301-12-065	65
M301-12-090	90
M301-12-120	120
M301-12-150	150
M301-12-180	180
M301-12-250	250
M301-12-300	300
M301-12-350	350

Order Example:
 I= 165

Order Code:
 M301-12-165

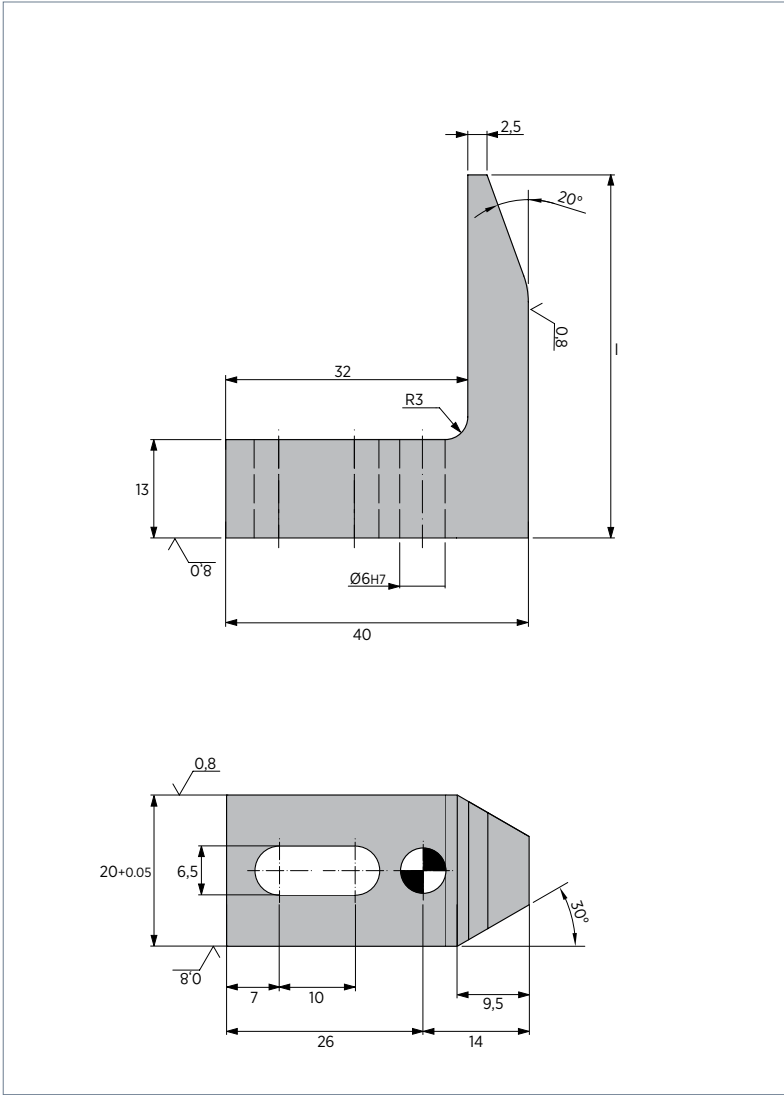
 Material :
 21MnCr5
 Hardened
 HRC 58 ÷ 60

CODE	l
M301-13-028	28
M301-13-038	38
M301-13-048	48
M301-13-058	58
M301-13-068	68
M301-13-078	78
M301-13-088	88

3

1 Material :
CK45
Hardened
HRC 58 ÷ 60



2 Material :
CK45
Hardened
HRC 54 ÷ 56

3 Material :
CK45
Hardened*
HRC 58 ÷ 60

4 Spring

5 Spring

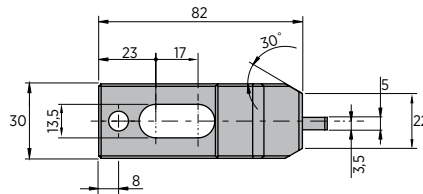
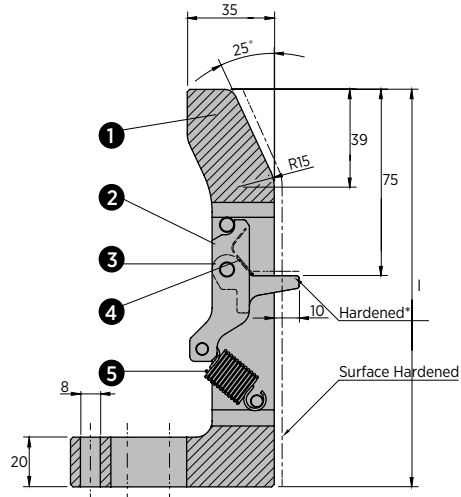

CODE	I	F1 (N)	F2 (N)
M301-14-160	160	5,90	18,50
M301-14-1601		10,00	30,00
M301-14-1602		22,00	65,00
M301-14-170	170	5,90	18,50
M301-14-1701		10,00	30,00
M301-14-1702		22,00	65,00
M301-14-180	180	5,90	18,50
M301-14-1801		10,00	30,00
M301-14-1802		22,00	65,00
M301-14-190	190	5,90	18,50
M301-14-1901		10,00	30,00
M301-14-1902		22,00	65,00
M301-14-200	200	5,90	18,50
M301-14-2001		10,00	30,00
M301-14-2002		22,00	65,00

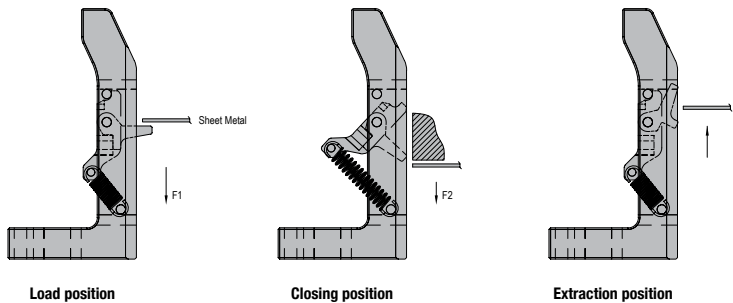

Order Example:
I= 160, F1=10

Order Code:
M301-14-1601

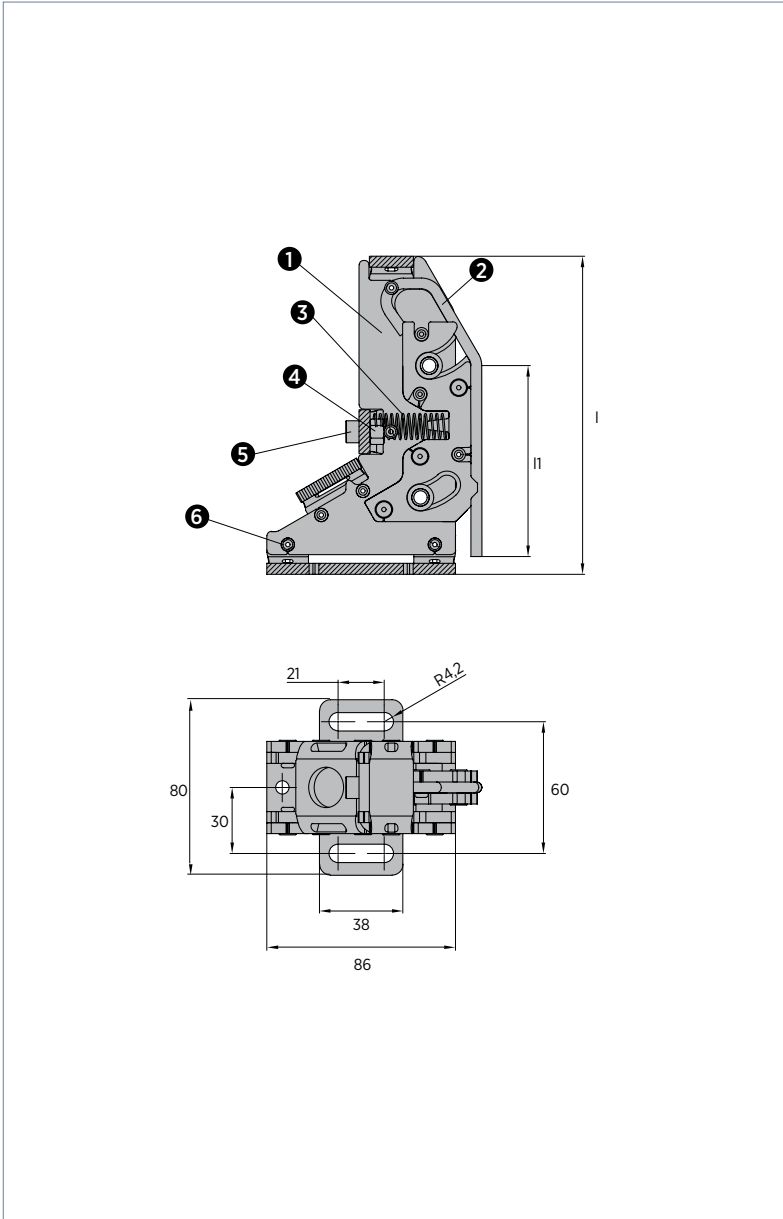

- 1** Material : S235
- 2** Material : 1.4021
Hardened
HRC 40-45
- 3** Material : Spring DIN 2098
- 4** Material : M6 DIN 934
- 5** Material : Screw M6x12 ISO 4762
- 6** Material : Rivet Ø4x14 DIN 7337



CODE	11	I
M301-15-145	87	145
M301-15-185	127	185
M301-15-225	167	225

3

- 1** Material : C45
- 2** Material : C45
- 3** Material : C15
- 4** Material : C15
- 5** Material : C15
- 6** Material : C-M8X40-12,9

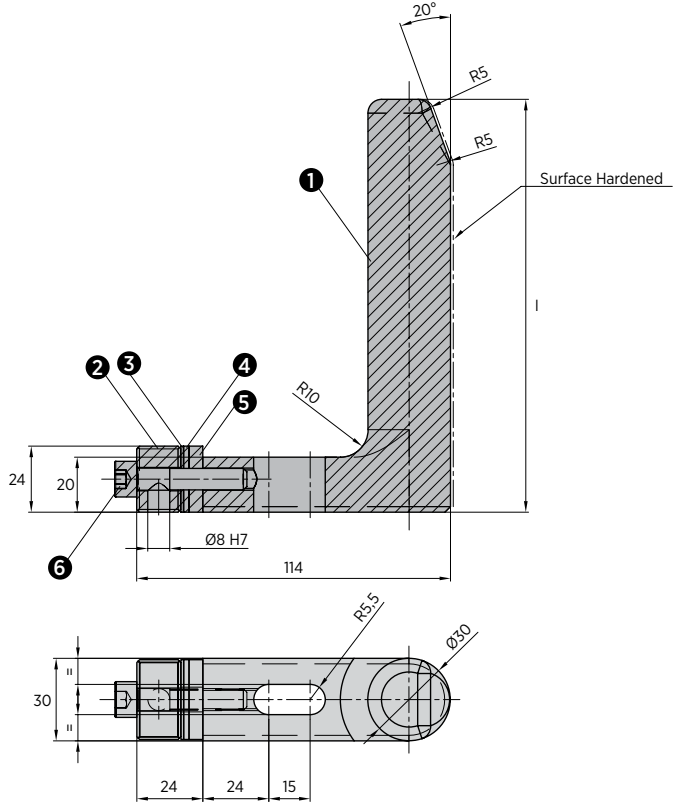

CODE	I
M301-16-065	65
M301-16-090	90
M301-16-120	120
M301-16-150	150
M301-16-190	190
M301-16-220	220

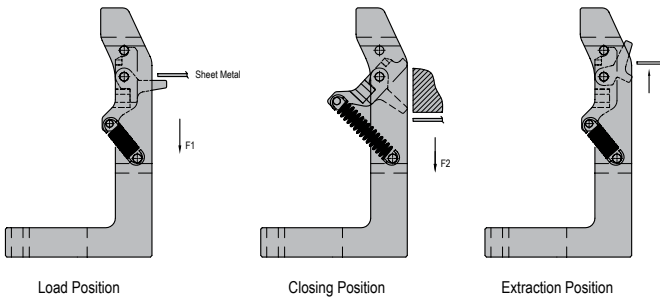
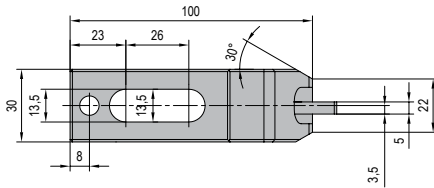
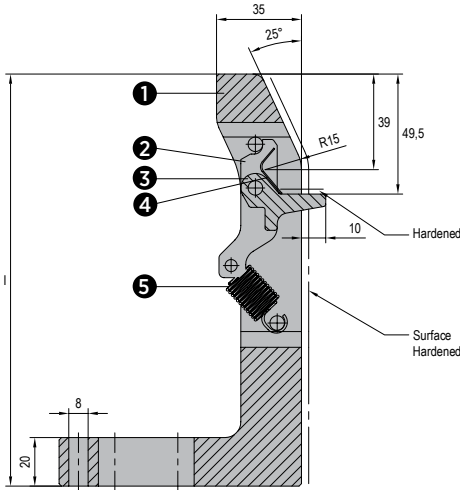

- 1** Material :
 CK45
 Hardened
 HRC 58 ± 60
- 2** Material :
 CK45
 Hardened
 HRC 54 ± 56
- 3** Material :
 CK45
 Hardened*
 HRC 58 ± 60
- 4** Spring **5** Spring



CODE	I	F1 (N)	F2 (N)
M301-17-160	160	5,90	18,50
M301-17-1601		10,00	30,00
M301-17-1602		22,00	65,00
M301-17-170	170	5,90	18,50
M301-17-1701		10,00	30,00
M301-17-1702		22,00	65,00
M301-17-180	180	5,90	18,50
M301-17-1801		10,00	30,00
M301-17-1802		22,00	65,00
M301-17-190	190	5,90	18,50
M301-17-1901		10,00	30,00
M301-17-1902		22,00	65,00
M301-17-200	200	5,90	18,50
M301-17-2001		10,00	30,00
M301-17-2002		22,00	65,00
M301-17-210	210	5,90	18,50
M301-17-2101		10,00	30,00
M301-17-2102		22,00	65,00
M301-17-250	250	5,90	18,50
M301-17-2501		10,00	30,00
M301-17-2502		22,00	65,00
M301-17-300	300	5,90	18,50
M301-17-3001		10,00	30,00
M301-17-3002		22,00	65,00

Order Example:
 I= 160, F1=10

Order Code:
 M301-17-1601

3

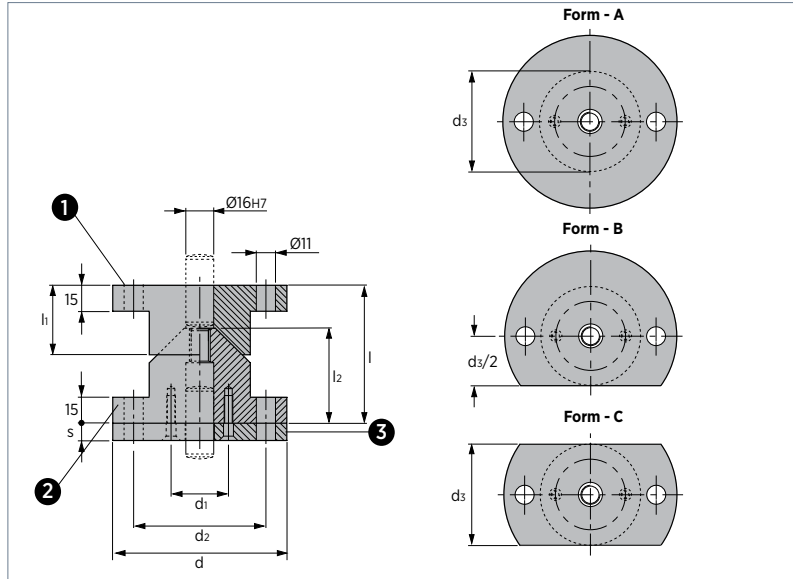

- 1** Material :
Forged
16MnCr5
- 2** Hardened
HRC 60 ± 64
- 3** Material :
CK45

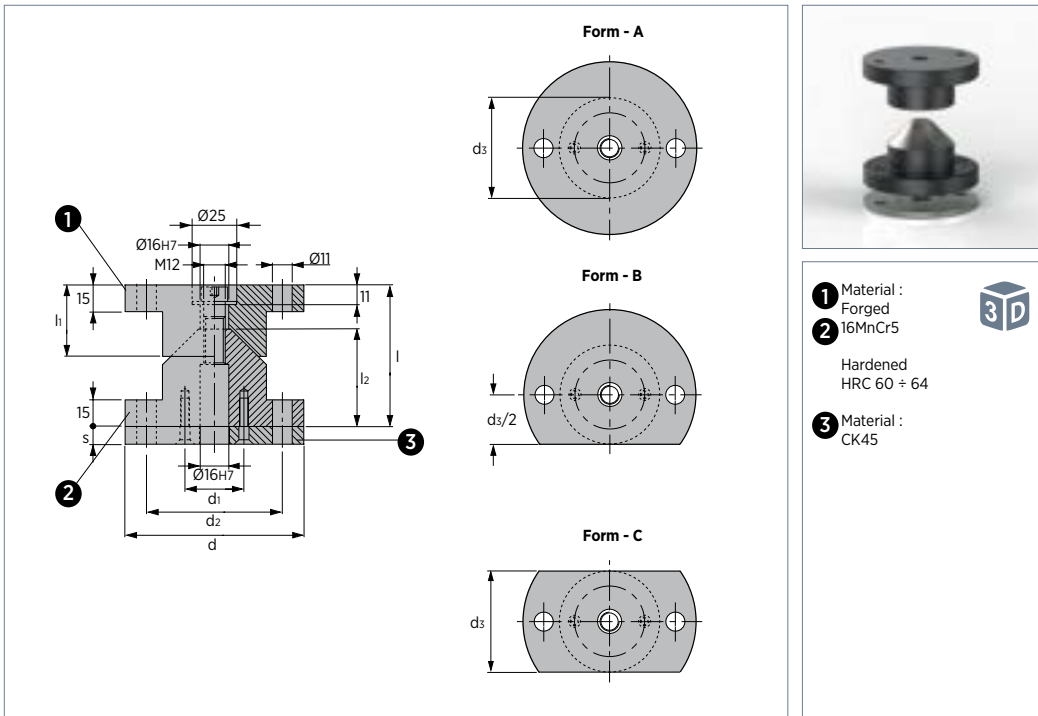

CODE	Form	d	l ±0,05	l ₁	l ₂	d ₁	d ₂	d _s	s +0,1
M302-01-100-000	A	100	80	40	55	40,5	76	58	5
M302-01-100-001	A	100	80	40	55	40,5	76	58	10,5
M302-01-100-002	C	100	80	40	55	40,5	76	58	10,5
M302-01-100-003	B	100	80	40	55	40,5	76	58	10,5
M302-01-100-100	B	100	80	40	55	40,5	76	58	5
M302-01-100-005	A	100	80	40	55	40,5	76	58	5,5
M302-01-100-010	A	100	80	40	55	40,5	76	58	9,8
M302-01-100-105	B	100	80	40	55	40,5	76	58	5,5
M302-01-100-110	B	100	80	40	55	40,5	76	58	9,8
M302-01-100-200	C	100	80	40	55	40,5	76	58	5
M302-01-100-205	C	100	80	40	55	40,5	76	58	5,5
M302-01-100-210	C	100	80	40	55	40,5	76	58	9,8
M302-01-120-000	A	120	90	50	65	50,5	96	78	5
M302-01-120-001	A	120	90	50	65	50,5	96	78	10,5
M302-01-120-002	C	120	90	50	65	50,5	96	78	10,5
M302-01-120-003	B	120	90	50	65	50,5	96	78	10,5
M302-01-120-005	A	120	90	50	65	50,5	96	78	5,5
M302-01-120-010	A	120	90	50	65	50,5	96	78	9,8
M302-01-120-105	B	120	90	50	65	50,5	96	78	5,5
M302-01-120-100	B	120	90	50	65	50,5	96	78	5
M302-01-120-110	B	120	90	50	65	50,5	96	78	9,8
M302-01-120-205	C	120	90	50	65	50,5	96	78	5,5
M302-01-120-210	C	120	90	50	65	50,5	96	78	9,8

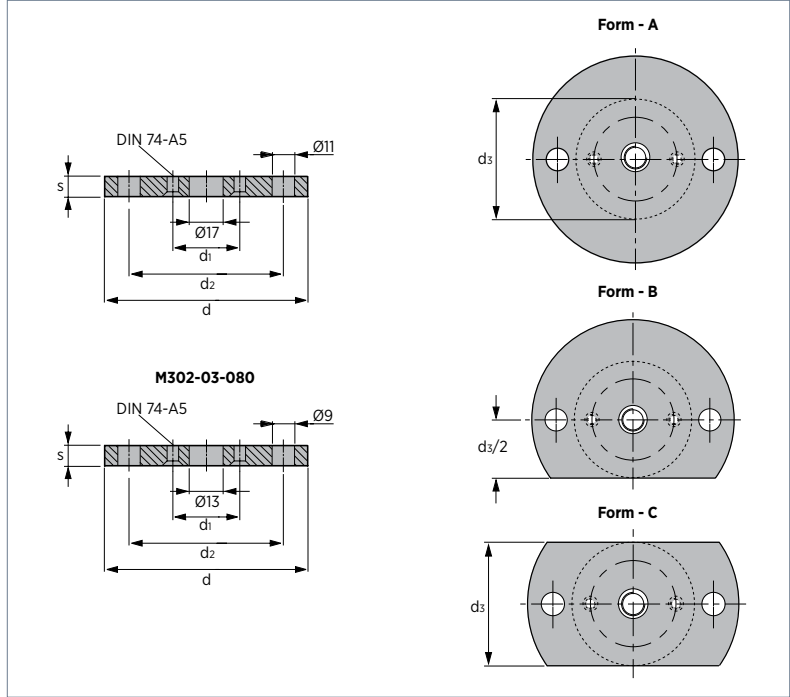

CODE	Form	d	l ±0,05	l ₁	l ₂	d ₁	d ₂	d _s	s +0,1
M302-02-100-005	A	100	80	40	55	40,5	76	58	5,5
M302-02-100-010	A	100	80	40	55	40,5	76	58	9,8
M302-02-100-015	A	100	80	40	55	40,5	76	58	10,5
M302-02-100-105	B	100	80	40	55	40,5	76	58	5,5
M302-02-100-110	B	100	80	40	55	40,5	76	58	9,8
M302-02-100-115	B	100	80	40	55	40,5	76	58	10,5
M302-02-100-205	C	100	80	40	55	40,5	76	58	5,5
M302-02-100-210	C	100	80	40	55	40,5	76	58	9,8
M302-02-100-215	C	100	80	40	55	40,5	76	58	10,5
M302-02-120-005	A	120	90	50	65	50,5	96	78	5,5
M302-02-120-010	A	120	90	50	65	50,5	96	78	9,8
M302-02-120-015	A	120	90	50	65	50,5	96	78	10,5
M302-02-120-105	B	120	90	50	65	50,5	96	78	5,5
M302-02-120-110	B	120	90	50	65	50,5	96	78	9,8
M302-02-120-115	B	120	90	50	65	50,5	96	78	10,5
M302-02-120-205	C	120	90	50	65	50,5	96	78	5,5
M302-02-120-210	C	120	90	50	65	50,5	96	78	9,8
M302-02-120-215	C	120	90	50	65	50,5	96	78	10,5

 Material :
 CK45

CODE	Form	d	d ₁	d ₂	d _s	s +0,1
M302-03-080-005	A	80	32	63	48	5
M302-03-080-055	A	80	32	63	48	5,5
M302-03-080-105	C	80	32	63	48	5
M302-03-080-155	C	80	32	63	48	5,5
M302-03-100-005	A	100	40,5	76	58	5,5
M302-03-100-010	A	100	40,5	76	58	9,8
M302-03-100-105	B	100	40,5	76	58	5,5
M302-03-100-110	B	100	40,5	76	58	9,8
M302-03-100-205	C	100	40,5	76	58	5,5
M302-03-100-210	C	100	40,5	76	58	9,8
M302-03-100-215	C	100	40,5	76	58	10,5
M302-03-120-005	A	120	50,5	96	78	5,5
M302-03-120-010	A	120	50,5	96	78	9,8
M302-03-120-105	B	120	50,5	96	78	5,5
M302-03-120-110	B	120	50,5	96	78	9,8
M302-03-120-205	C	120	50,5	96	78	5,5
M302-03-120-210	C	120	50,5	96	78	9,8
M302-03-120-215	C	120	50,5	96	78	10,5

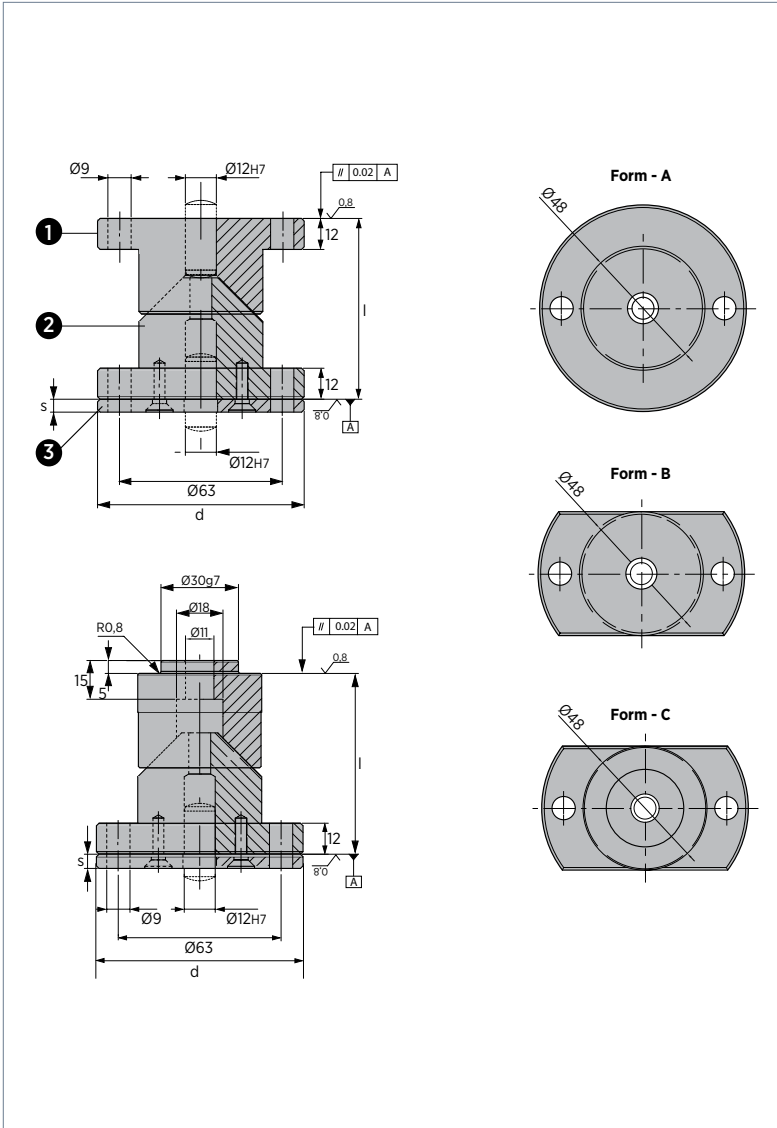

- 1** Material :
Forged
16MnCr5
- 2** Hardened
HRC 60 ÷ 62
- 3** Material :
CK45



3

CODE	Form	d	s	I ±0,05
M302-08-080-005	A	80	5	70
M302-08-080-055	A	80	5,5	70
M302-08-080-105	B	80	5	70
M302-08-080-155	B	80	5,5	70
M302-08-080-205	C	80	5	70
M302-08-080-255	C	80	5,5	70

3

 Material :
 16MnCr5

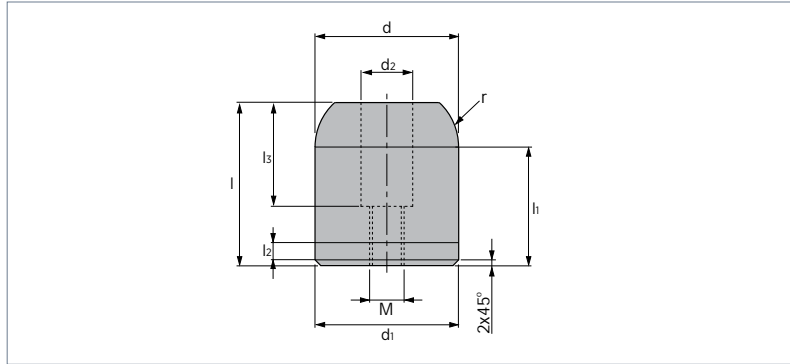
 Hardened
 HRC 58 ± 60

CODE	d j6	d1 -0,05 / -0,1	l	l1	l2	l3	d2 ±0,2	M	r
M303-01-022045	22	22	45	37,5	8	25	14	M10	12,5
M303-01-032050	32	32	50	40	10	35	18	M12	20
M303-01-040055	40	40	55	40	10	35	18	M12	20
M303-01-050055	50	50	55	40	10	35	18	M12	20

 Material :
 16MnCr5

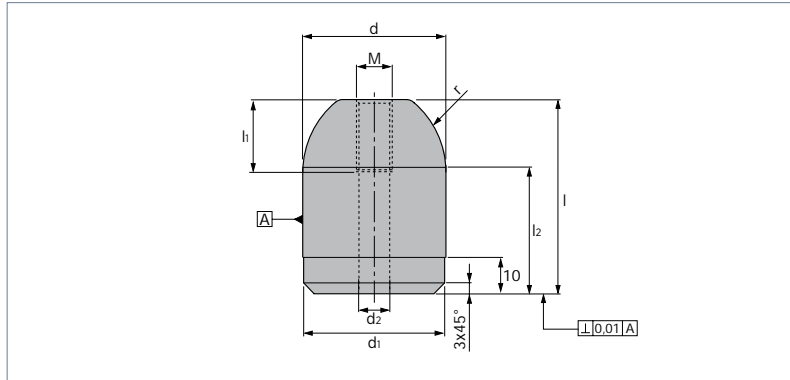
 Hardened
 HRC 58 ± 60

CODE	d h6	l	l1	l2	d1 -0,05	d2	M	r
M303-02-022045	22	45	16	35	22	7	M8	15
M303-02-022055	22	55	16	45	22	7	M8	15
M303-02-032050	32	50	20	35	32	9	M10	20
M303-02-040055	40	55	20	35	40	9	M10	25
M303-02-040065	40	65	20	45	40	9	M10	25
M303-02-040085	40	85	20	65	40	9	M10	25
M303-02-050055	50	55	20	35	50	9	M10	25
M303-02-056080	56	80	20	60	56	9	M10	30

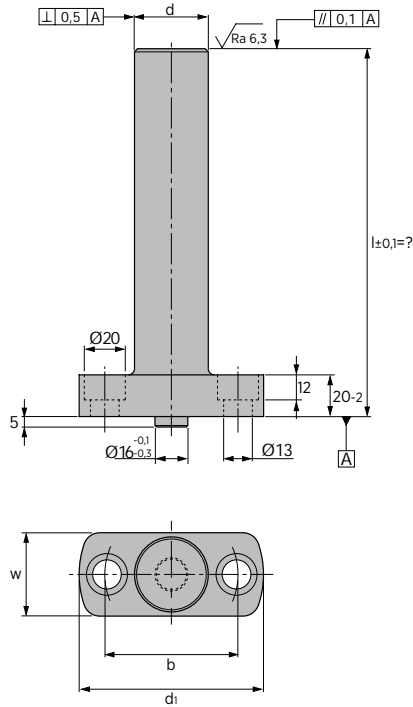

Material :
 CK45
 Forged
 800 ÷ 1000 N/mm²



Length (l) is given by the customer;

Max. Length: 360 mm

CODE	d +2	w	b	d ₁ ±1	Max. Load (kN)
M304-01-036-l	36	40	65	90	50
M304-01-045-l	45	50	75	100	70

Order Example:
 d= 36, l= 205

Order Code:
 M304-01-036-205

3

 Material :
 CK45
 Forged
 $800 \div 1000 \text{ N/mm}^2$

Length (l) is given by the customer;

Max. Length: 440 mm

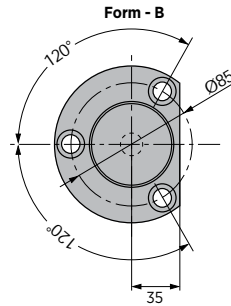
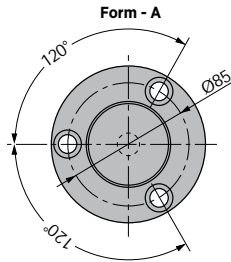
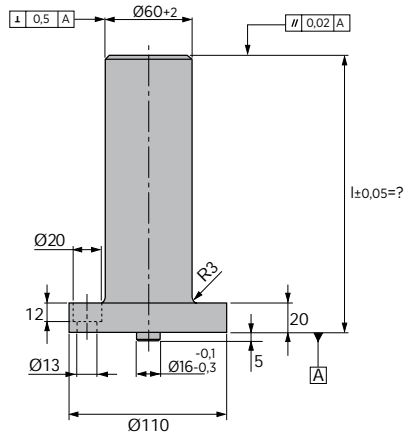

CODE	Form	Max. Load (kN)
M304-07-00-1	A	80
M304-07-01-1	B	80

Order Example:
 Form= A, l= 205

Order Code:
 M304-07-00-205

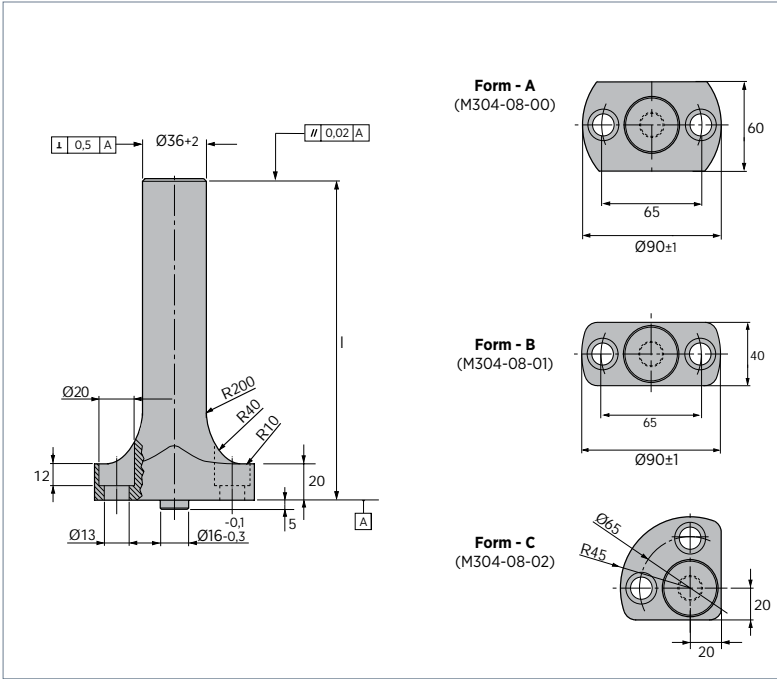

Material :
 42CrMo4+QT
 Forged
 800 ÷ 1000 N/mm²



Different lengths on request;

Max. Length: 360 mm



CODE	l ±0,05	Max. Load (kN)
M304-08-??-150	150	50
M304-08-??-155	155	50
M304-08-??-160	160	50
M304-08-??-165	165	50
M304-08-??-170	170	50
M304-08-??-175	175	50
M304-08-??-180	180	50
M304-08-??-185	185	50
M304-08-??-190	190	50
M304-08-??-195	195	50
M304-08-??-200	200	50
M304-08-??-205	205	50

CODE	l ±0,05	Max. Load (kN)
M304-08-??-210	210	50
M304-08-??-215	215	50
M304-08-??-220	220	50
M304-08-??-225	225	50
M304-08-??-230	230	50
M304-08-??-235	235	50
M304-08-??-240	240	50
M304-08-??-245	245	50
M304-08-??-250	250	50
M304-08-??-255	255	50
M304-08-??-260	260	50
M304-08-??-265	265	50

CODE	l ±0,05	Max. Load (kN)
M304-08-??-270	270	50
M304-08-??-275	275	50
M304-08-??-280	280	50
M304-08-??-285	285	50
M304-08-??-290	290	50
M304-08-??-295	295	50
M304-08-??-300	300	50
M304-08-??-310	310	50
M304-08-??-320	320	50
M304-08-??-330	330	50
M304-08-??-340	340	50
M304-08-??-350	350	50
M304-08-??-360	360	50

Order Example:
 Form= A, l= 205

Order Code:
 M304-08-00-205

3

 Material :
 CK45
 Forged
 $800 \div 1000 \text{ N/mm}^2$

 Length (l) is given by the
 customer;

Max. Length: 600 mm

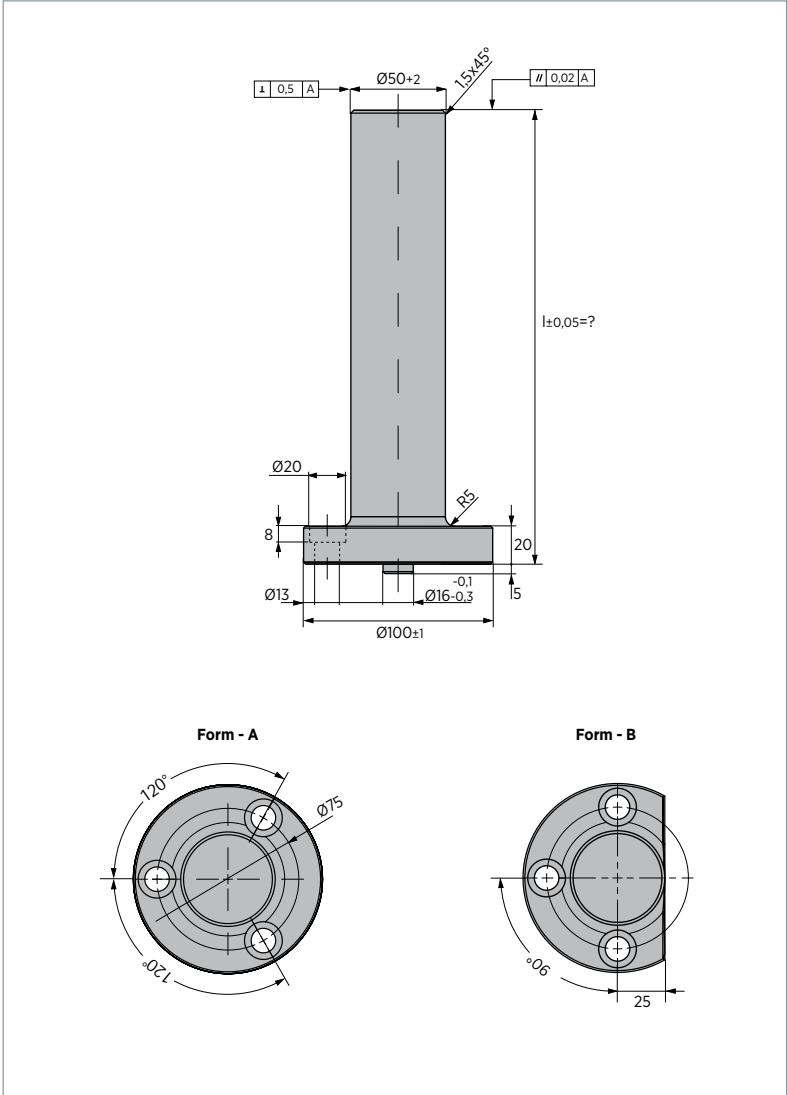

CODE	Form	Max. Load (kN)
M304-09-00-I	A	80
M304-09-01-I	B	80

Order Example:
 Form= A, l= 220

Order Code:
 M304-09-00-220

 Material:
 1.7227 (42CrMoS4+QT)

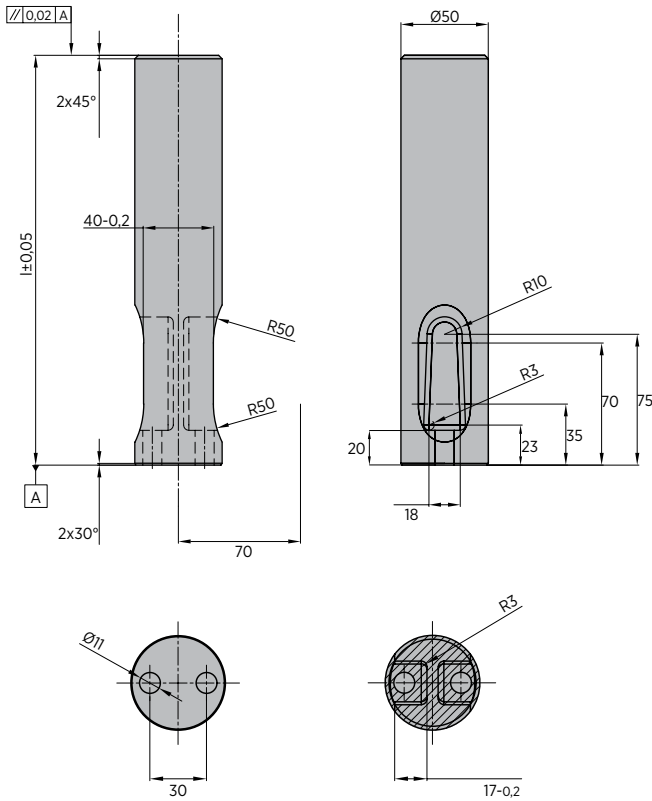
3

CODE	Max. Load (kN)
M304-10-L	80

Order Example:
 l= 220

Order Code:
 M304-10-220

3

- 1** Material (Sleeve):
CK45
Hardened
HRC 58 ÷ 62
- 2** Material (Bushes):
Bronze with Non-Liquid
Lubricant
HB ≈ 190
- 3** Gas Spring
- 4** DIN 472
- 5** M10x60 DIN 912
- 6** Material :
90MnCrV8
Hardened
HRC 54 ÷ 60

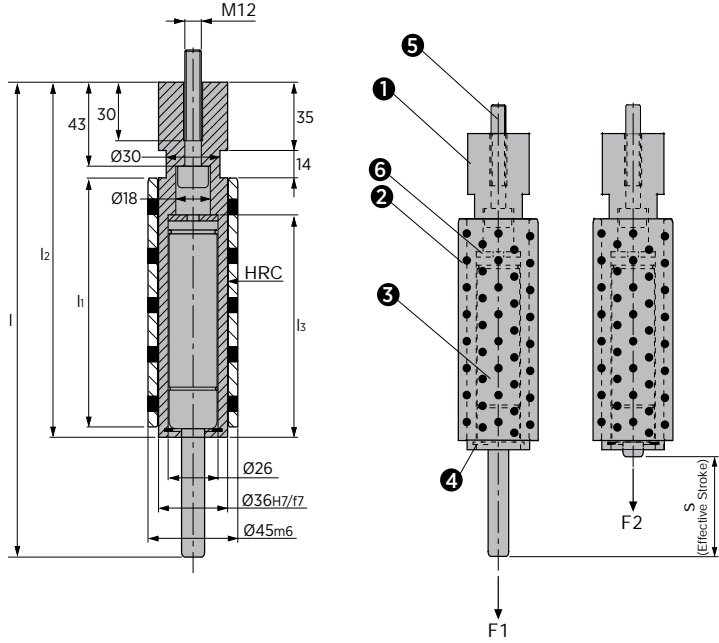

CODE	l	h	l ₂	l ₃	F1 (daN)	F2 (daN)	s
M305-04-50050	240	115	182	118	50	68	50
M305-04-50100	240	115	182	118	100	136	50
M305-04-50150	240	115	182	118	150	204	50
M305-04-50200	240	115	182	118	200	272	50
M305-04-65050	274	145	200	135	50	68	65
M305-04-65100	274	145	200	135	100	136	65
M305-04-65150	274	145	200	135	150	204	65
M305-04-65200	274	145	200	135	200	272	65
M305-04-80050	314	170	220	155	50	68	80
M305-04-80100	314	170	220	155	100	136	80
M305-04-80150	314	170	220	155	150	204	80
M305-04-80200	314	170	220	155	200	272	80

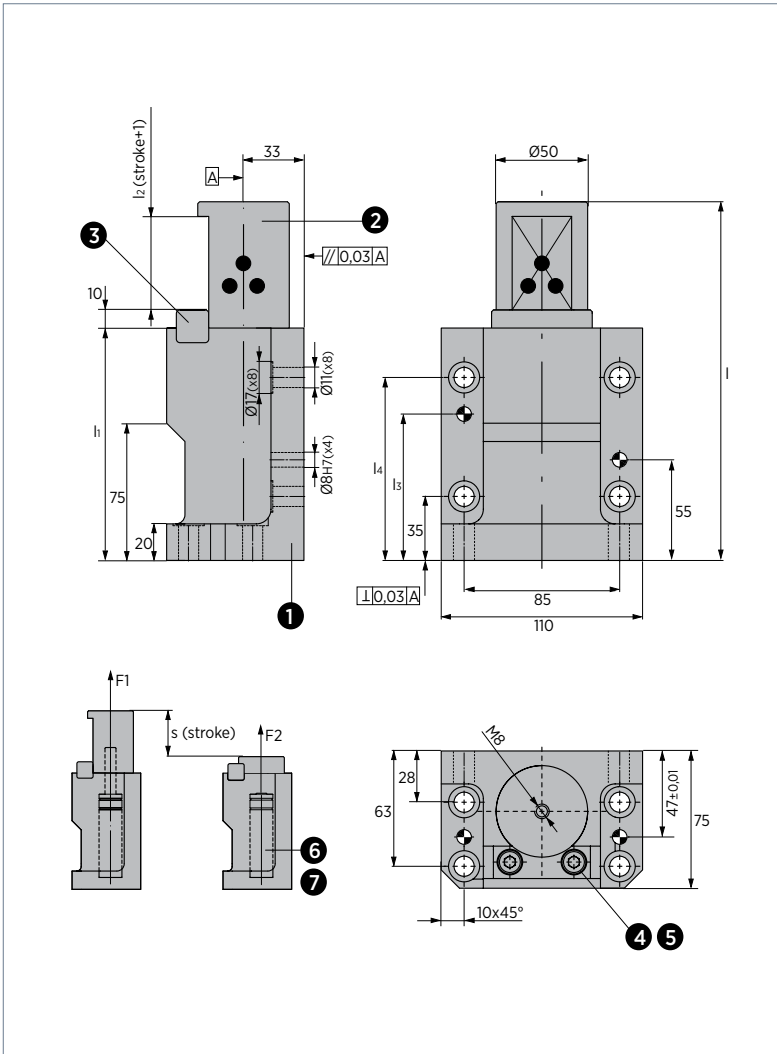

- 1** Material : CK45
- 2** Material : Bronze + Graphite
HB > 190
- 3** Material : 36NiCrMo4
- 4** M8x30 DIN 912
- 5** Schnorr Ø8
- 6** Gas Spring
- 7** M6x12 DIN 7991



CODE	l	li	lz	ls	ll	F1 (daN)	F2 (daN)	s
M305-05-50050	196	127	51	80	100	50	86	50
M305-05-50100	196	127	51	80	100	100	172	50
M305-05-50150	196	127	51	80	100	150	258	50
M305-05-50200	196	127	51	80	100	200	344	50
M305-05-80050	256	157	81	110	130	50	86	80
M305-05-80100	256	157	81	110	130	100	172	80
M305-05-80150	256	157	81	110	130	150	258	80
M305-05-80200	256	157	81	110	130	200	344	80

3
1 Material :
 CK45

2 Material :
 Bronze + Graphite
 HB > 190

3 Material :
 36NiCrMo4

4 M8x30 DIN 912

5 Schnorr Ø8

6 Gas Spring

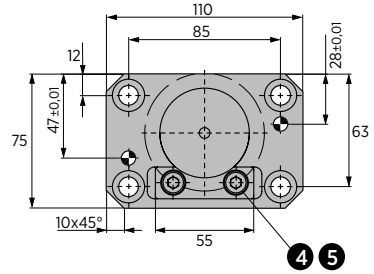
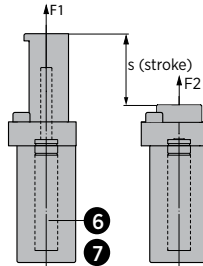
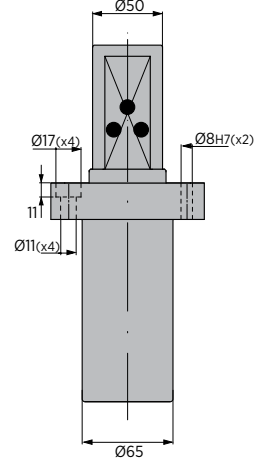
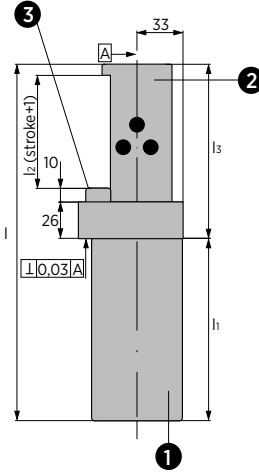
7 M6x12 DIN 7991

CODE	l	h	l ₂	l ₃	F ₁ (daN)	F ₂ (daN)	s
M305-06-50050	196	101	51	95	50	86	50
M305-06-50100	196	101	51	95	100	172	50
M305-06-50150	196	101	51	95	150	258	50
M305-06-50200	196	101	51	95	200	344	50
M305-06-80050	256	131	81	125	50	86	80
M305-06-80100	256	131	81	125	100	172	80
M305-06-80150	256	131	81	125	150	258	80
M305-06-80200	256	131	81	125	200	344	80

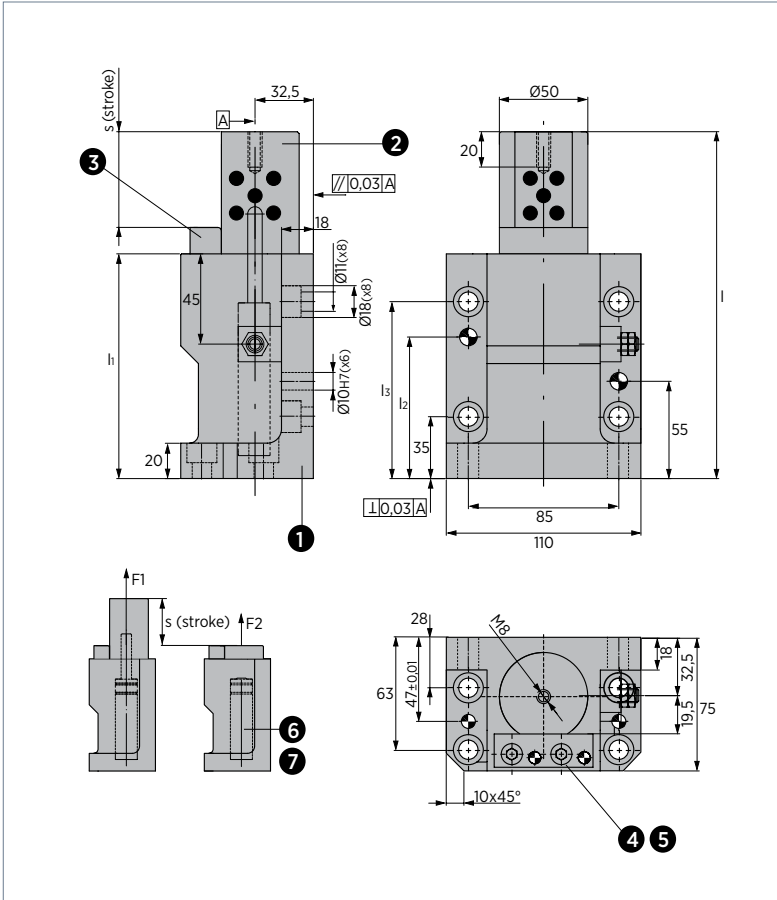
3

- 1** Material : CK45
- 2** Material : Bronze + Graphite
HB > 190
- 3** Material : 36NiCrMo4
- 4** M8x30 DIN 912
- 5** Schnorr Ø8
- 6** Gas Spring
- 7** M6x12 DIN 7991



CODE	l	h ₁	l ₂	l ₃	F1 (daN)	F2 (daN)	s
M305-07-50050	196	125	80	100	50	65	50
M305-07-50100	196	125	80	100	100	135	50
M305-07-50150	196	125	80	100	150	200	50
M305-07-50200	196	125	80	100	200	260	50
M305-07-80050	256	155	110	130	50	65	80
M305-07-80100	256	155	110	130	100	135	80
M305-07-80150	256	155	110	130	150	200	80
M305-07-80200	256	155	110	130	200	260	80
M305-07-100050	296	175	130	150	50	65	100
M305-07-100100	296	175	130	150	100	135	100
M305-07-100150	296	175	130	150	150	200	100
M305-07-100200	296	175	130	150	200	260	100

3

- 1** Material : CK45
- 2** Material : Bronze + Graphite
HB > 190
- 3** Material : 36NiCrMo4
- 4** M8x30 DIN 912
- 5** Schnorr Ø8
- 6** Gas Spring
- 7** M6x12 DIN 7991

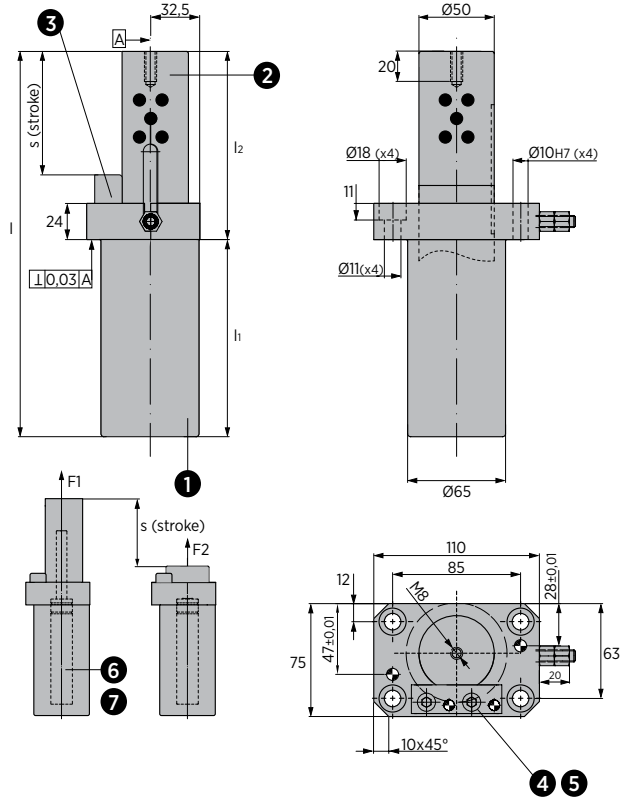

CODE	l	l ₁	l ₂	F ₁ (daN)	F ₂ (daN)	s
M305-08-50050	196	101	95	50	65	50
M305-08-50100	196	101	95	100	135	50
M305-08-50150	196	101	95	150	200	50
M305-08-50200	196	101	95	200	260	50
M305-08-80050	256	131	125	50	65	80
M305-08-80100	256	131	125	100	135	80
M305-08-80150	256	131	125	150	200	80
M305-08-80200	256	131	125	200	260	80
M305-08-100050	296	151	145	50	65	100
M305-08-100100	296	151	145	100	135	100
M305-08-100150	296	151	145	150	200	100
M305-08-100200	296	151	145	200	260	100

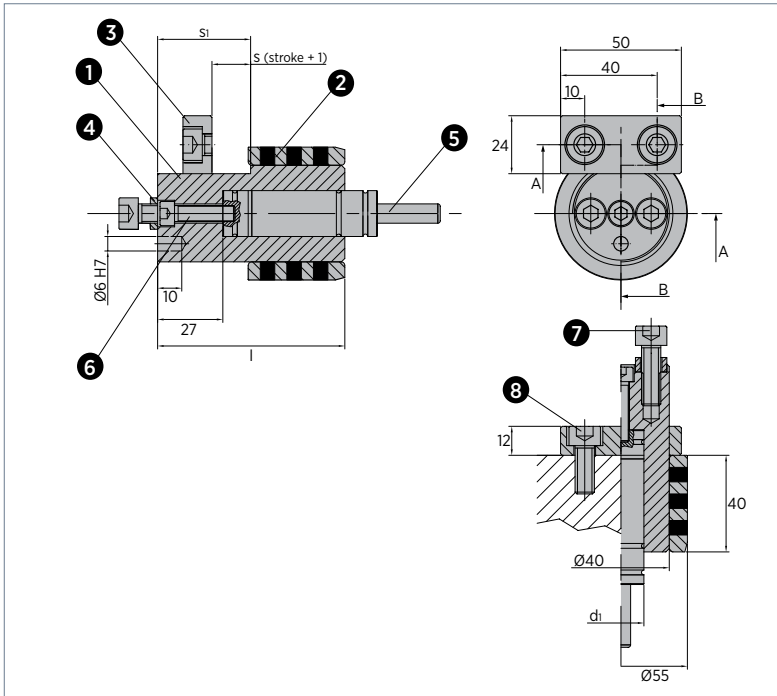
1 Material :
16MnCr5

 Hardened
HRC 54 ÷ 56

2 Material (Bush Self-lubricating) :
Bronze + Graphite
HB > 190

3 Retainer (2.172.472)

4 Material (Locating Ring) :
115CrV3

5 Gas Spring

6 M6x25 DIN 912

7 M8x25 DIN 912

8 M8x20 DIN 912

CODE	d ₁ +1 / +1,5	l ±0,1	s	s ₁
M305-09-010090	19	64	9	25
M305-09-010200	25	64	9	25
M305-09-015090	19	68,5	13,5	29,5
M305-09-015200	25	68,5	13,5	29,5
M305-09-025090	19	77,5	22,5	38,5
M305-09-025200	25	77,5	22,5	38,5
M305-09-038090	19	89	34	50
M305-09-038200	25	89	34	50
M305-09-050090	19	100	45	63
M305-09-050200	25	100	45	63
M305-09-063090	19	113,5	58,5	74,5
M305-09-063200	25	113,5	58,5	74,5
M305-09-080090	19	130	75	91
M305-09-080200	25	130	75	91
M305-09-100090	19	150	95	111
M305-09-100200	25	150	95	111
M305-09-125090	19	175	120	136
M305-09-125200	25	175	120	136

3

- 1 Material :
42CrMo4
800 ÷ 1000 N/mm²
- 2 Material :
CK45
Washer: 5xØ13,2xØ30
- 3 Screw: M12x20 DIN 912

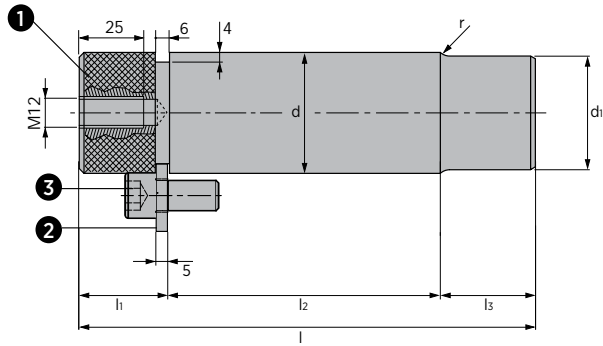

CODE	d _{e8}	l	l ₁	l ₂	l ₃	d ₁ +0,05	r	Dynamic load (kN)
M306-02-032105	32	105	22	58	25	29	4	3
M306-02-032122	32	122	22	75	25	29	4	3
M306-02-040139	40	139	32	75	32	37	5	5
M306-02-040159	40	159	32	95	32	37	5	5
M306-02-050167	50	167	32	95	40	47	6	7,5
M306-02-050192	50	192	32	120	40	47	6	7,5
M306-02-063202	63	202	32	120	50	60	6	12,5
M306-02-063237	63	237	32	155	50	60	6	12,5

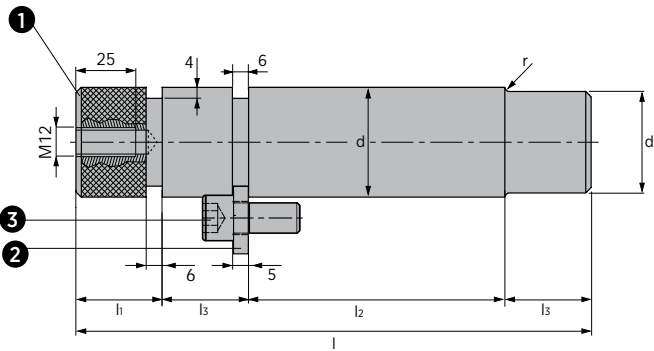

- 1** Material :
42CrMo4
800 ÷ 1000 N/mm²
- 2** Material :
CK45
Washer: 5xØ13,2xØ30
- 3** Screw: M12x20 DIN 912

3

CODE	d _{e8}	l	h ₁	l ₂	l ₃	d ₁ +0,05	r	Dynamic load (kN)
M306-03-032130	32	130	22	58	25	29	4	3
M306-03-032147	32	147	22	75	25	29	4	3
M306-03-040171	40	171	32	75	32	37	5	5
M306-03-040191	40	191	32	95	32	37	5	5
M306-03-050207	50	207	32	95	40	47	6	7,5
M306-03-050232	50	232	32	120	40	47	6	7,5
M306-03-063252	63	252	32	120	50	60	6	12,5
M306-03-063287	63	287	32	155	50	60	6	12,5

3

- 1 Material: 36NiCrMo4
- 2 3 Material: St37
- 4 Material: CK45
- 5 Elastomer 92SH
- 6 DIN 935 cl. 8.8
- 7 DIN 94



A and B are given by the customer.

*Respect the max. load.

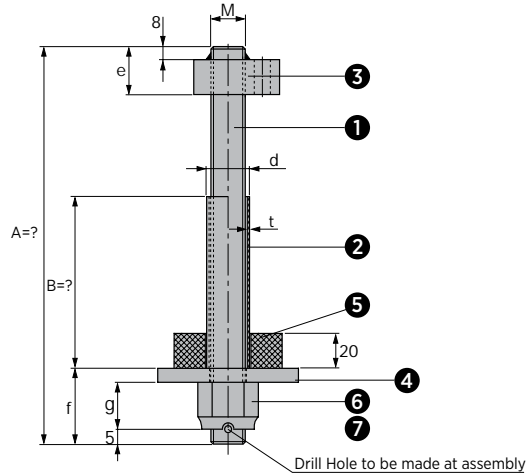
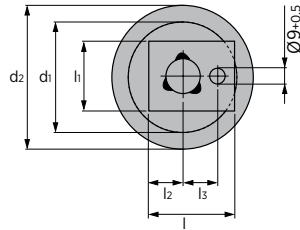

CODE	dxt	l	li	l2	l3 ±0,5	d1	d2	e	f	g	M	Max. Load (kg)
M307-01-16AAABBB	22x2	50	35	20	20	50	65	28	30	19	M16	250
M307-01-20AAABBB	25x2	50	40	20	20	63	82	28	35	22	M20	450
M307-01-24AAABBB	30x2,5	50	45	20	20	80	105	28	42	27	M24	750
M307-01-30AAABBB	38x3,5	63	50	28	26	100	130	33	50	33	M30	1250

Order Example:
 M= 20, A= 247, B= 110

Order Code:
 M307-01-20247110

 Material:
 CK45

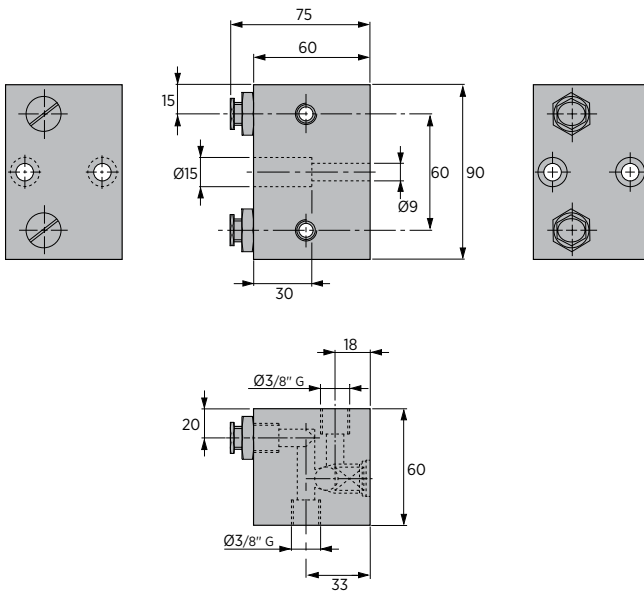
3

CODE
M308-01-090-060

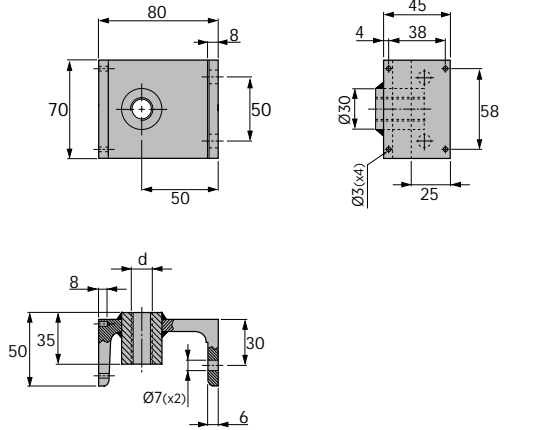
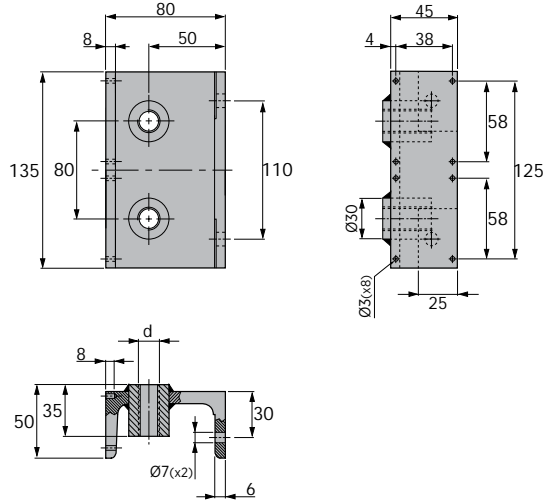
 Material :
 St 37

Form - A

Form - B

CODE	Form	d
M308-07-080070	A	G 3/8"
M308-07-080135	B	G 1/4"



1 Material :
CK45



2 Elastomer 92 Shore

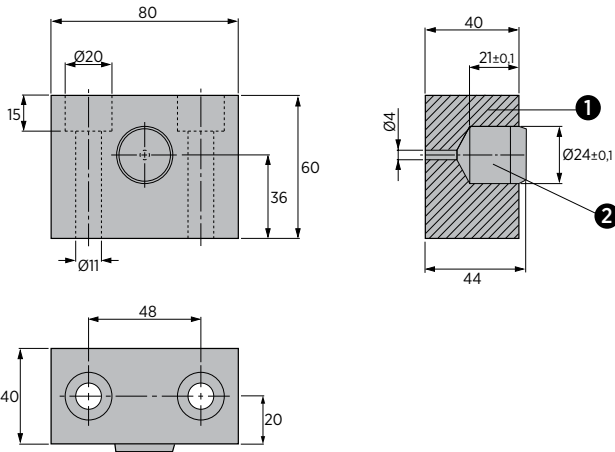

CODE	Fmax. (kN)	Max. Energy Absorbed (J)
M309-02-040080	3	4,8

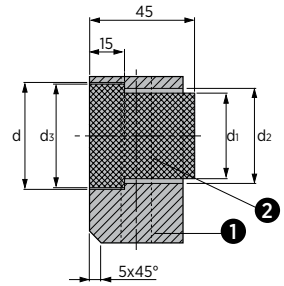
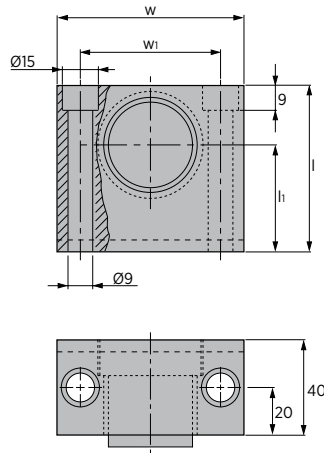

3
1 Material :
CK45

2 Elastomer 90 Shore

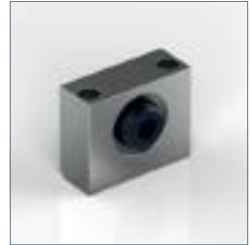
CODE	w	d	l	h	w ₁	d ₁	d ₂	d ₃	F _{max.} (kN)	Max. Energy Absorbed (J)
M309-04-040065	65	35	60	40	45	27	30	34	5,2	13
M309-04-040075	75	45	70	45	55	36	40	44	9,8	24,5

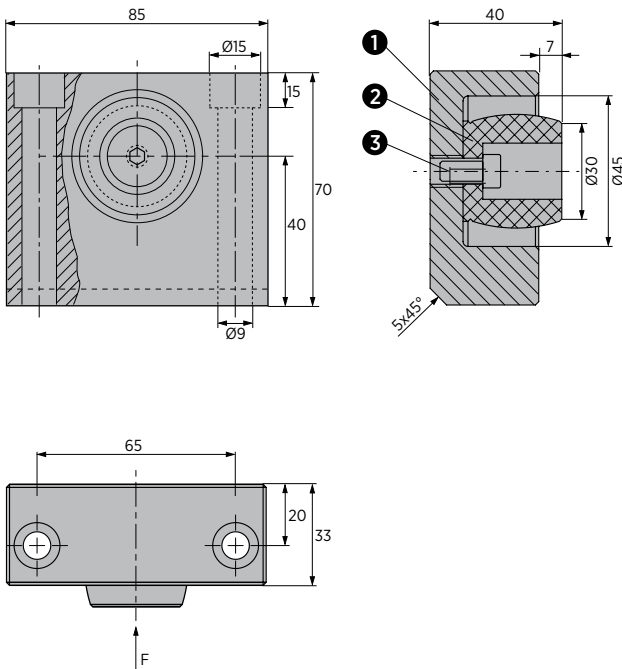

3



- 1** Material: CK45
- 2** Shock Absorber
- 3** M6x12 DIN 912



CODE	Fmax. (kN)	Max. Energy Absorbed (J)	Max. Stroke (mm)
M309-05-033085	3,75	8	7

3

- 1 Material: CK45
- 2 Shock Absorber
- 3 M10x30 DIN 912

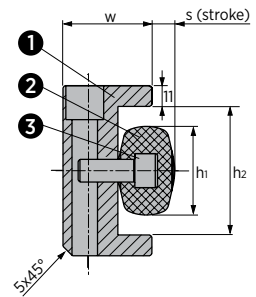
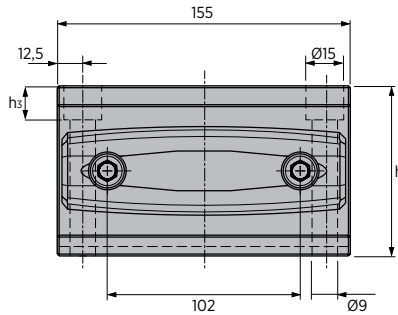
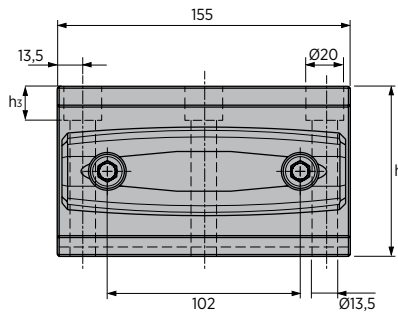
Form - A

Form - B

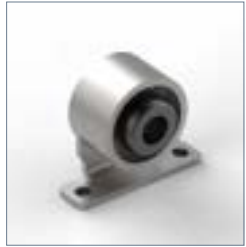
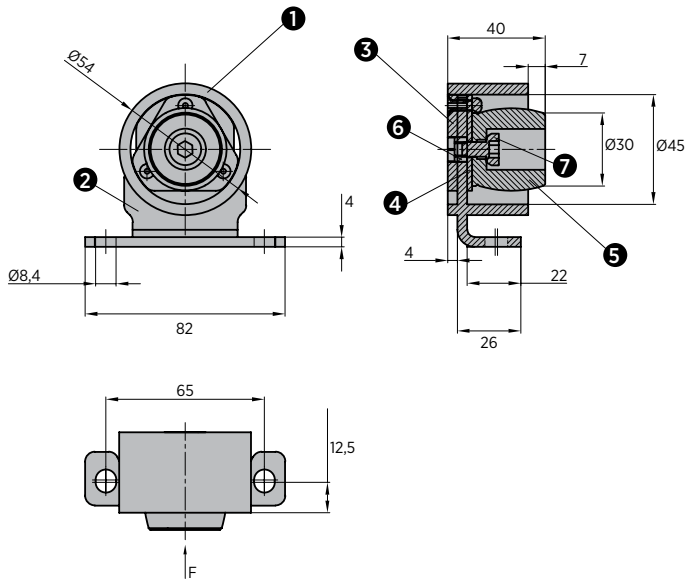
CODE	Form	w	h	h ₁	h ₂	h ₃	Max. Energy/Hub (J/Hub)	Max. Stroke (mm)
M309-06-0467155	A	46,7	80	47	58	9	210	10,3
M309-06-047155	A	47	90	52	68	19	230	7
M309-06-0471551	B	47	90	47	68	18	210	14



3

- 1** Material : S355
- 2** Material : S355
- 3** Material : S355
- 4** Material : S235/DC01
- 5** Shock Absorber
- 6** Material : M6 DIN 934
- 7** Material : Screw ZKS-M6x10

CODE	Fmax. (Kn)	Max. Energy Absorbed (J)	Max. Stroke (mm)
M309-07-054033	3.75	8	7

3

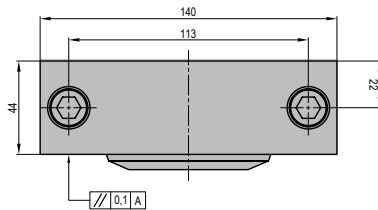
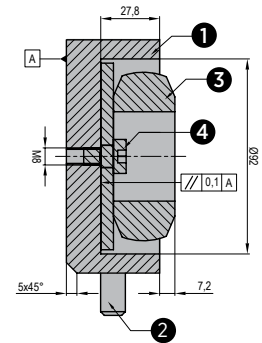
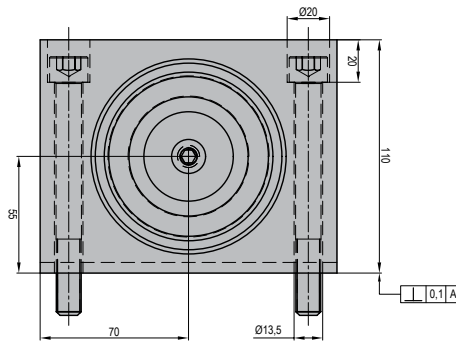
- 1 Material:
S355J2C+C
- 2 Screw
M12 x 110 DIN EN ISO 4762
- 3 Co-Polyester-Elastomer/
TecsPak SD80-9
Elastomer not Included
- 4 Screw M8x8
Screws not Included



CODE	Fmax. (kN)	Max. Energy Absorbed (J)	Max. Stroke (mm)
M309-08-044140	22	60	8

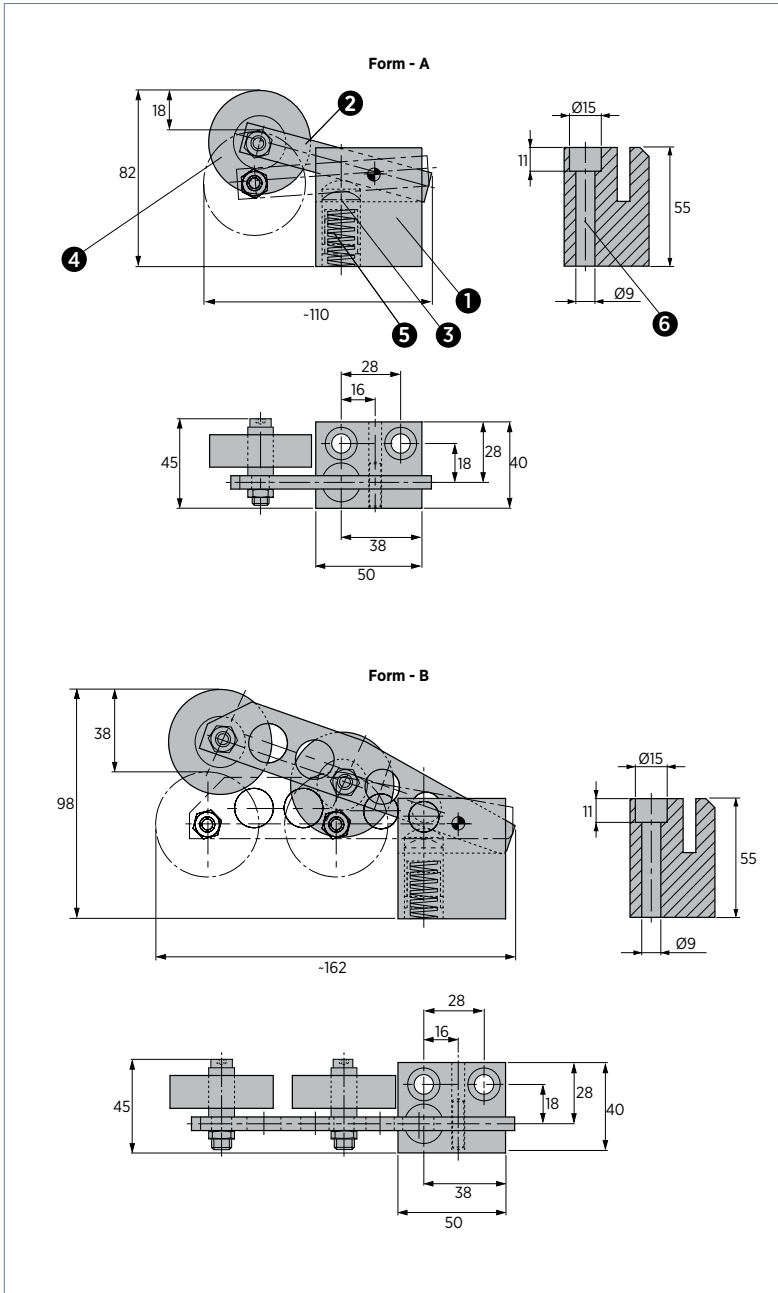

- 1** Material: C15
- 2** Material: S235JRG2K
- 3** Material: 42CrMo4
- 4** Roller
- 5** Spring
- 6** Screws M8x60 DIN 912



3

CODE	Form
M310-01-001	A
M310-01-002	B

3

- 1** Material: C15
- 2** Material: S235JRG2K
- 3** Material: 42CrMo4
- 4** Roller
- 5** Spring
- 6** Screws M8x60 DIN 912

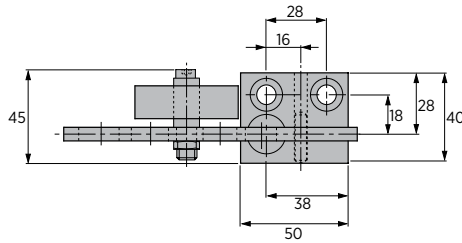
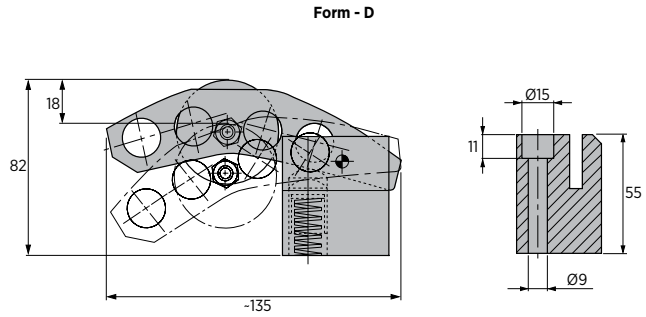
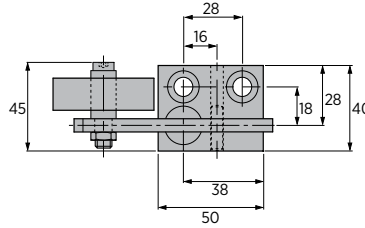
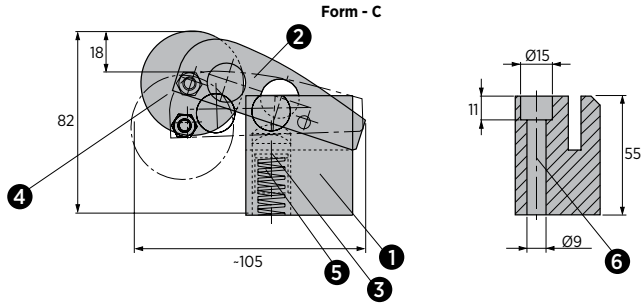

CODE	Form
M310-01-003	C
M310-01-004	D

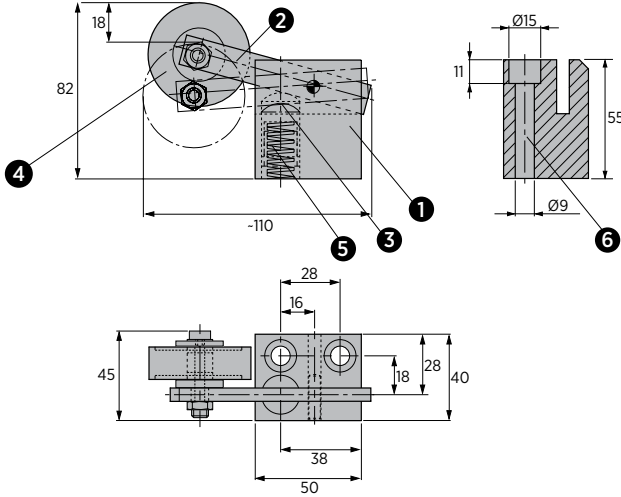
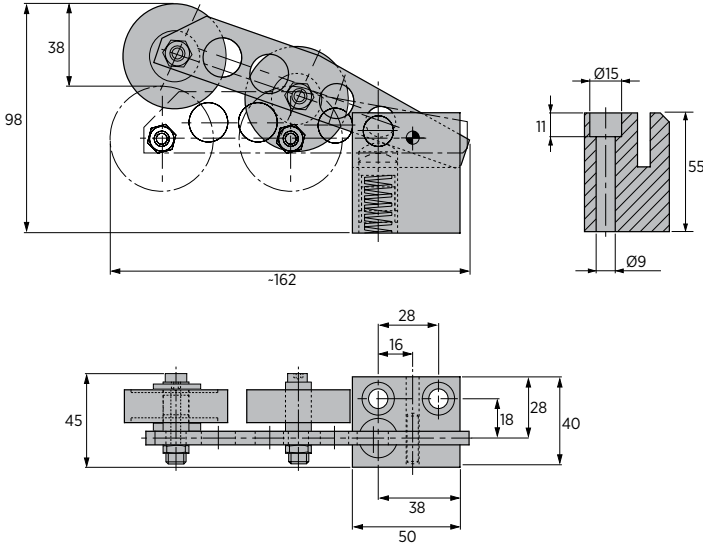
Form - A

Form - B

3

- 1** Material: C15
- 2** Material: S235JRG2K
- 3** Material: 42CrMo4
- 4** Roller
- 5** Spring
- 6** Screws M8x60 DIN 912



CODE	Form
M310-01-010	A
M310-01-011	B

3

- 1** Material: C15
- 2** Material: S235JRG2K
- 3** Material: 42CrMo4
- 4** Roller
- 5** Spring
- 6** Screws M8x60 DIN 912

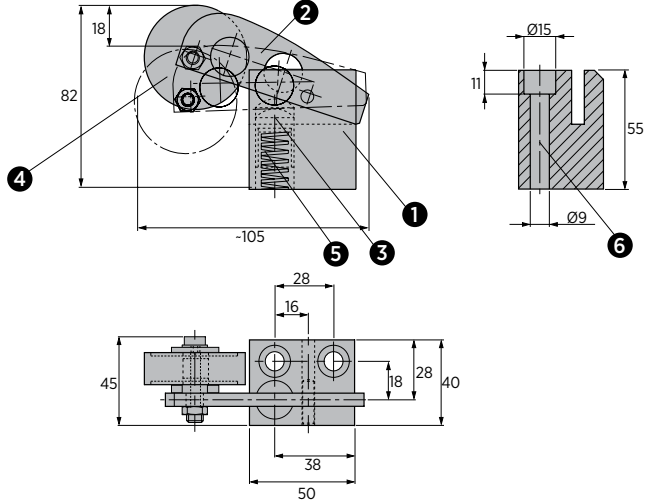
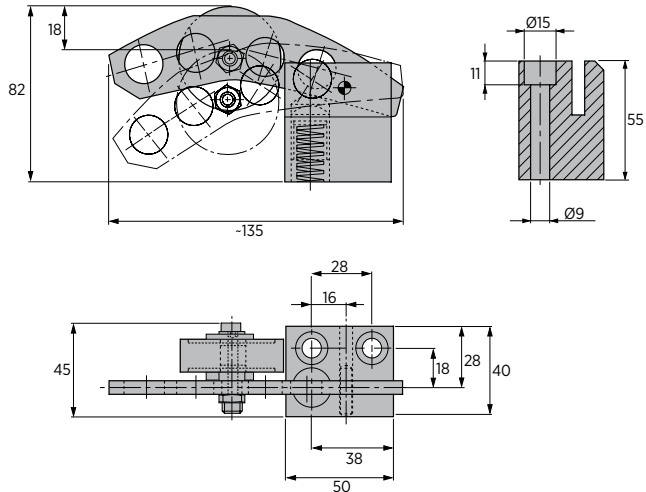
Form - C

Form - D

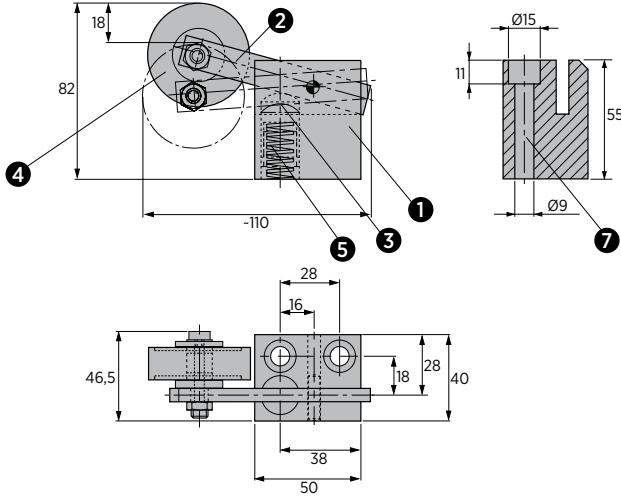
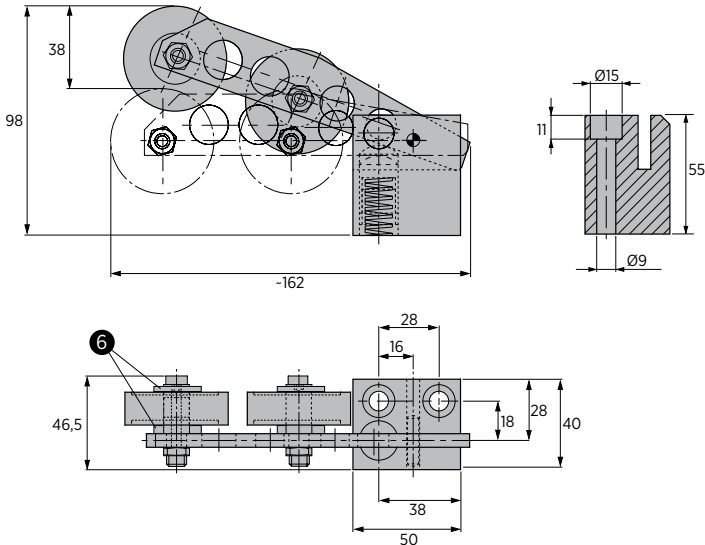
CODE	Form
M310-01-012	C
M310-01-013	D

Form - A

Form - B

3

- 1** Material: C15
- 2** Material: S235JRG2K
- 3** Material: 42CrMo4
- 4** Roller
- 5** Spring
- 6** Material: Steel
- 7** Screws M8x60 DIN 912



CODE	Form
M310-01-020	A
M310-01-021	B

3

- 1** Material: C15
- 2** Material: S235JRG2K
- 3** Material: 42CrMo4
- 4** Roller
- 5** Spring
- 6** Material: Steel
- 7** Screws M8x60 DIN 912

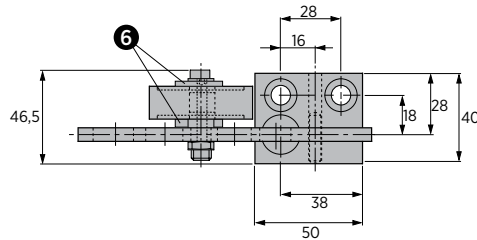
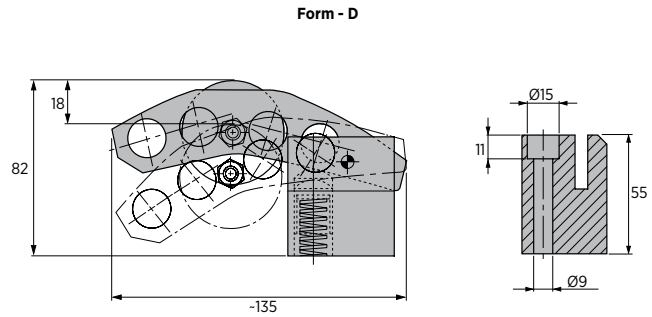
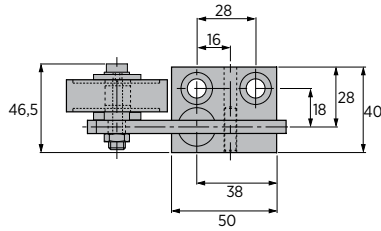
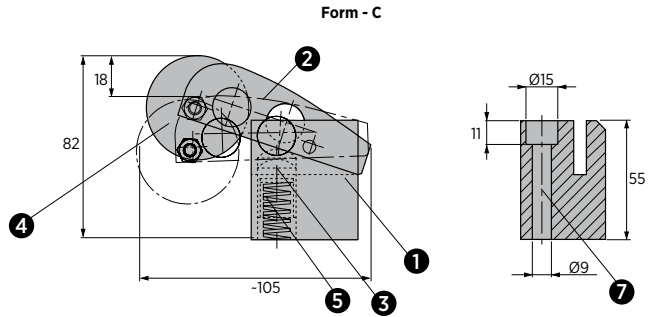

CODE	Form
M310-01-022	C
M310-01-023	D

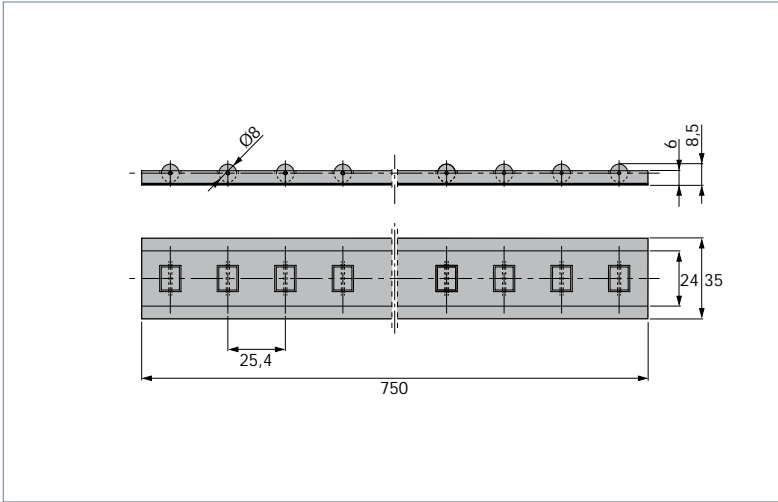
 Material :
 Steel

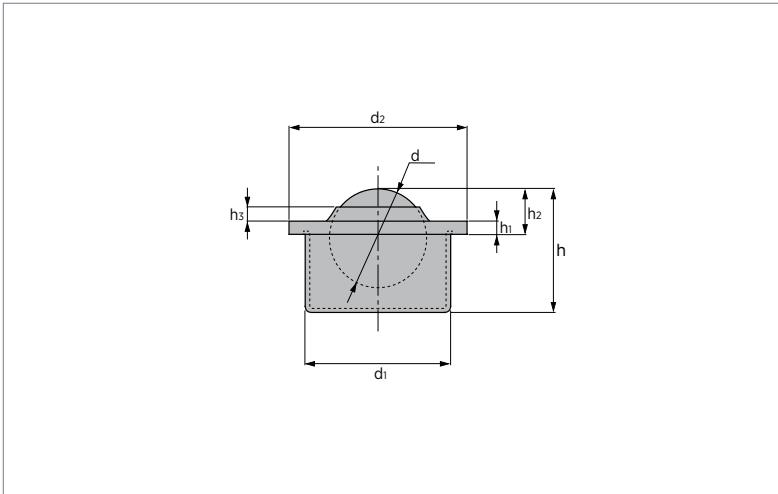
3
CODE
M310-03-35750

 Material :
 Steel

CODE	d	h	d ₁	d ₂	h ₁	h ₂	h ₃	Max. Load (daN)
M310-04-0015	15	21,5	24±0,065	31	2,8	9,5±0,2	3,5	50
M310-04-0030	30	37,5	45±0,080	55	4	13,8±0,3	4,3	250

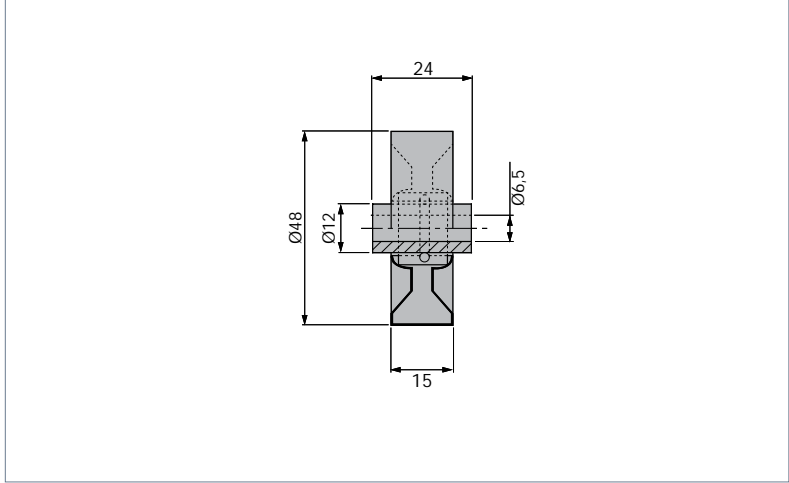
3

 Material :
 Steel

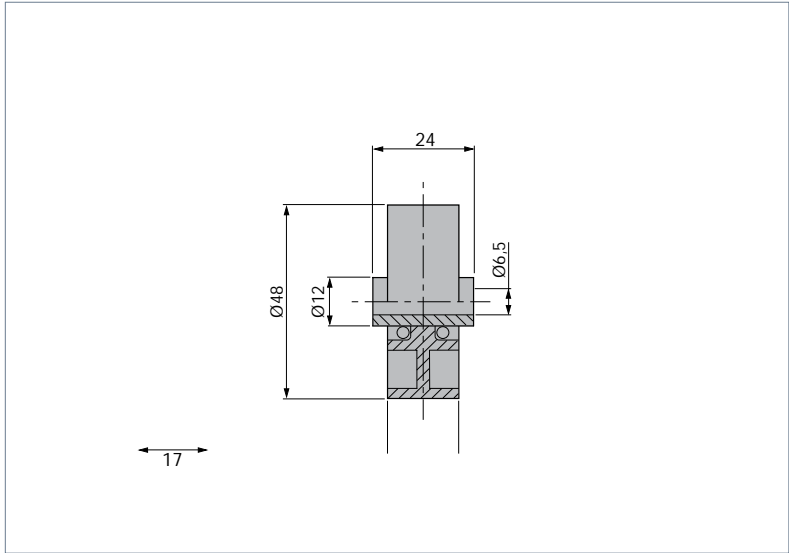
CODE	Max. Load (daN)
M310-05-001	25

 Material :
 Polypropylene

CODE	Max. Load (daN)
M310-06-001	20



1 Material:
Steel+Vulkollan



2 Roller Bearing 6200 2RS

3 I30 DIN 472

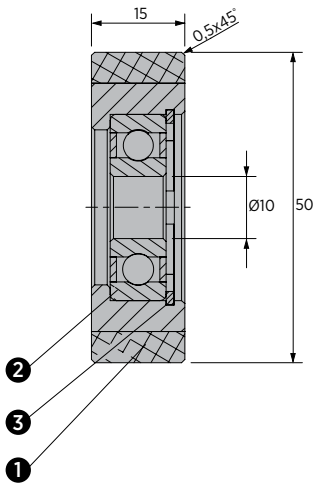

3

CODE	Max. Load (daN)
M310-08-001	70

3

1 Material:
St 37

2 3 Washers for M6

4 Nut for M6

5 Screw M6x40 DIN 912

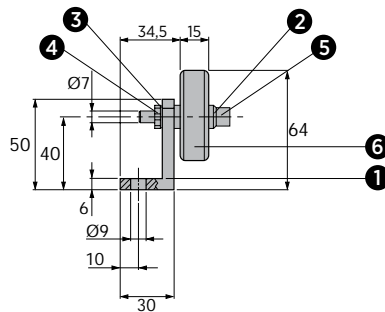
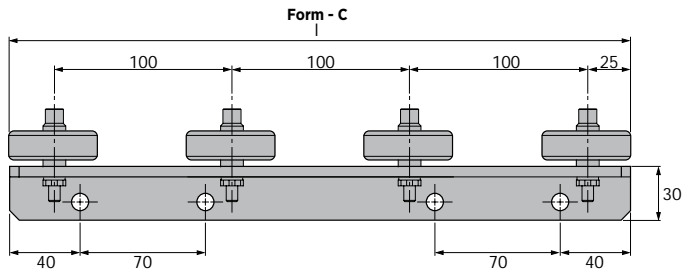
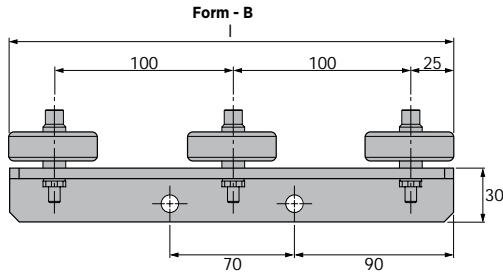
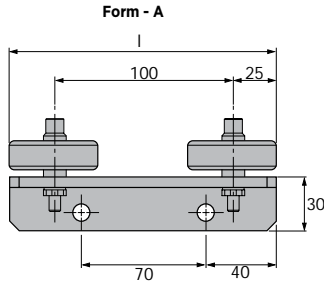
6 Material: Steel -
M310-05-001

CODE	Form	l	Max. Load (daN)
M310-08-064-150	A	150	50
M310-08-064-250	B	250	75
M310-08-064-350	C	350	100

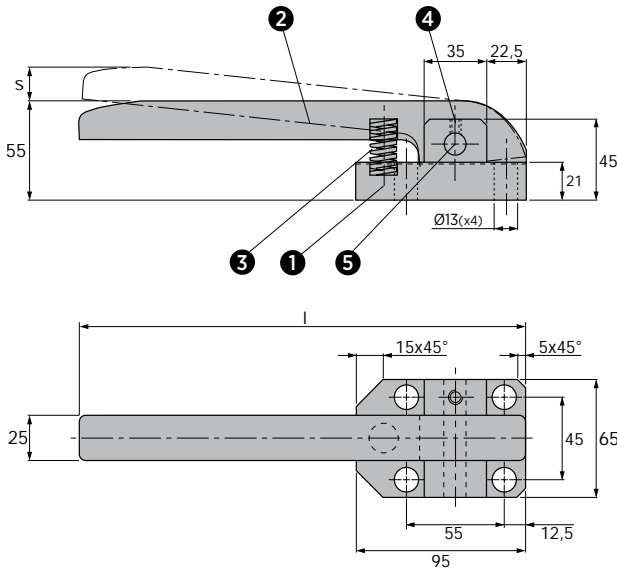

- 1** Material : CK45
- 2** Material: Bronze - HB>190
- 3** Spring
- 4** M6x8 DIN 913
- 5** Ø12x60 DIN 6325



3

CODE	l	s	Spring	Spring Initial Force (N)	Spring Final Force (N)
M310-09-01-001	250	18	TV016044	79	123
M310-09-01-002	250	18	B16044	270	420
M310-09-01-003	300	30	B16044	240	420

3

- 1** Steel or Resin (POM)
- 2** Steel
- 3** Steel
- 4** G Type Retaining Ring (G-8)

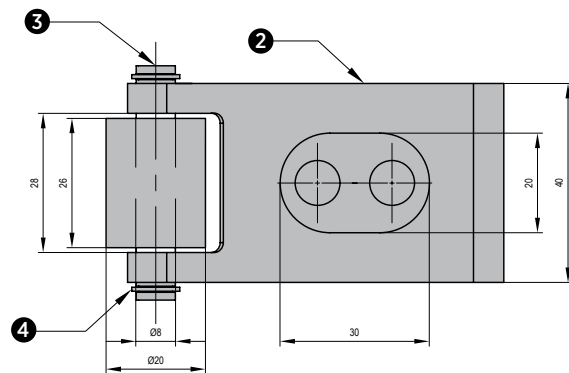
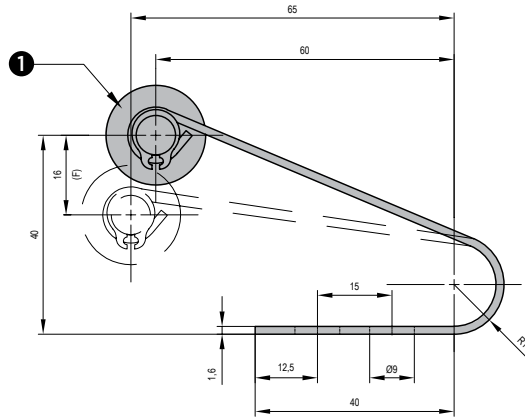

CODE	F max	Type
M310-10-016001	16	Steel
M310-10-016002	16	Resin

 Material :
 CK45

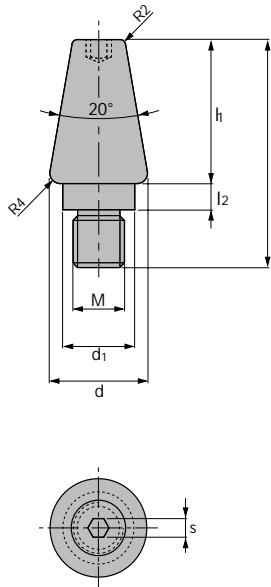
3

CODE	d	l	l ₁	l ₂	d ₁	M	s	Elastomer ø
M311-01-012056	28	56	30	8	19	M12	6	63
M311-01-016074	32	74	40	10	22	M16	8	80-100
M311-01-020100	38	100	55	15	28	M20	10	125-140

3

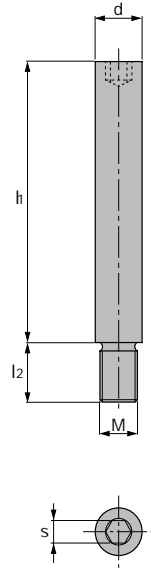
 Material :
 CK45

d	h										l ₂	M	s
6	20	25	32	40	-	-	-	-	-	-	6	M4	3
8	20	25	32	40	50	-	-	-	-	-	9	M6	4
10	20	25	32	40	50	63	-	-	-	-	15	M8	5
13	-	-	32	40	50	63	80	95	-	-	15	M10	6
16	-	25	32	40	50	63	80	95	118	140	180	M12	8
20	-	-	32	40	50	63	80	95	118	140	180	M16	10
25	-	-	32	40	50	63	80	95	118	140	180	M20	14

Order Example:
 d= 10, h= 50

Order Code:
 M311-05-10050



3

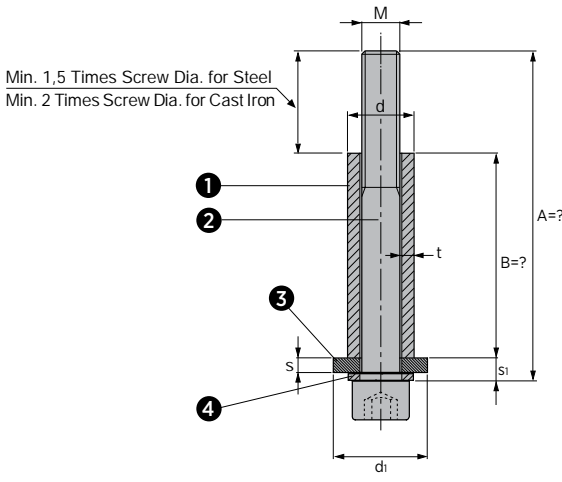

- 1 Material : St37
 - 2 DIN 912 cl. 12.9
 - 3 Material: CK45
 - 4 DIN 127
- A and B are given by the customer.



CODE	dxt	d _i	M	s	s ₁	Max. Load (kg)
M312-03-10AAABBB	16x2,5	25	M10	4	5,6	100
M312-03-12AAABBB	20x3,5	30	M12	6	7,7	150
M312-03-16AAABBB	28x5,5	40	M16	6	8,1	250

Order Example:
 M= 12, A= 110, B= 76

Order Code:
 M312-03-12110076

3

- ❶ Material : St37
 - ❷ DIN 912 cl. 12.9
 - ❸ Material: Elastomer 92SH
 - ❹ Material : CK45
 - ❺ DIN 127
- A and B are given by the customer.



Min. 1,5 Times Screw Dia. for Steel
 Min. 2 Times Screw Dia. for Cast Iron

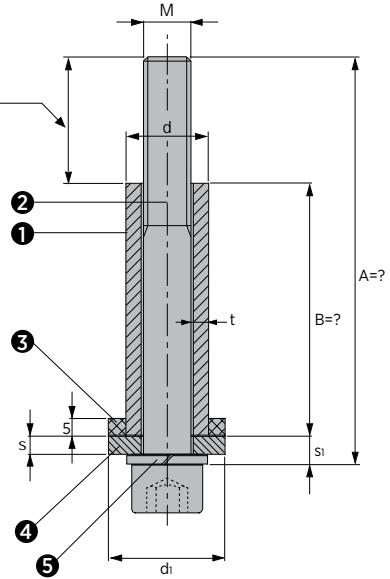

CODE	dxt	d1	M	s	s1	Max. Load (kg)
M312-08-10AAABBB	16x2,5	32	M10	4	6,5	100
M312-08-12AAABBB	20x3,5	36	M12	6	8,5	150
M312-08-16AAABBB	28x5,5	45	M16	6	9,5	250

Order Example:
 M= 12, A= 110, B= 76

Order Code:
 M312-08-12110076

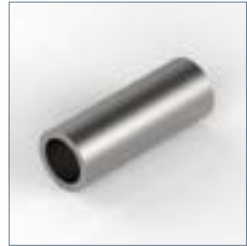
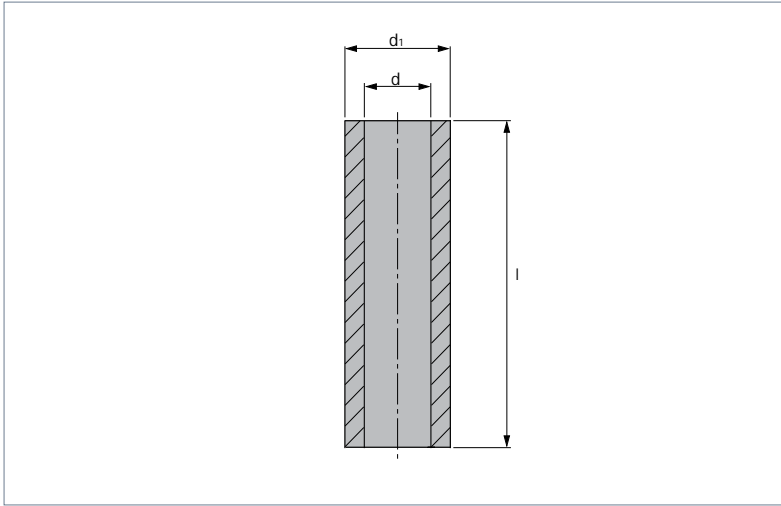
 Material :
 St35.4

Different lengths on request.

Order Example:
 d1= 20, l= 80

Order Code:
 M313-01-020080

3

d	6,4	9	11	13	17	22	26	32
d1	10	13	16	20	25	30	36	42
Screw	M6	M8	M10	M12	M16	M20	M24	M30
l±0,1								
27	•							
30		•	•					
33	•		•	•				
38	•		•	•				
40		•	•					
44	•		•	•				
48	•		•	•	•			
50		•	•	•	•	•		
61	•		•	•	•			
63		•	•	•	•	•		
70					•	•		
72	•		•	•	•	•	•	
80	•	•	•	•	•	•	•	
90			•	•	•	•	•	
95					•			
100		•	•	•	•	•	•	
105					•			
115					•			
125			•	•	•	•	•	
135					•			
150			•	•	•	•	•	•
155					•			
175					•	•	•	
195					•			
200			•	•	•	•	•	•
215					•			
225					•	•	•	
235					•			
250					•	•	•	
255					•			

3

 Material :
 ST35.4
 Surface hardened.
 HRC 56 ± 60

Different lengths on request.

Order Example:
 d= 20, l= 80

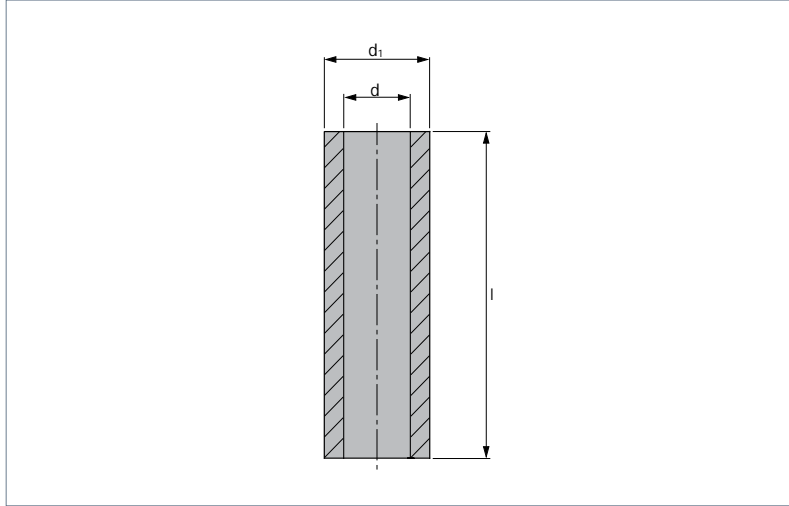
Order Code:
 M313-02-020080

d	6,4	9	11	13	17	22	26	32
d ₁	10	13	16	20	25	30	36	42
Screw	M6	M8	M10	M12	M16	M20	M24	M30
l±0,1								
27	•							
30		•	•					
33	•		•	•				
38	•		•	•				
40		•	•					
44	•		•	•				
48	•		•	•	•			
50		•	•	•	•	•		
61	•		•	•	•			
63		•	•	•	•	•		
70					•	•		
72	•		•	•	•	•	•	
80	•	•	•	•	•	•	•	
90			•	•	•	•	•	
95					•			
100		•	•	•	•	•	•	
105					•			
115					•			
125			•	•	•	•	•	
135					•			
150			•	•	•	•	•	•
155					•			
175					•	•	•	
195					•			
200			•	•	•	•	•	•
215					•			
225					•	•	•	
235					•			
250					•	•	•	
255					•			

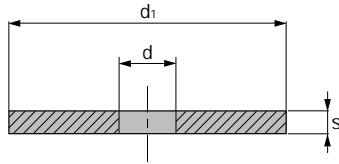
 Material :
 CK45

3

CODE	d	d ₁	s	Elastomer Ø
M313-04-020004	6,5	20	4	16
M313-04-025004	8,5	25	4	20
M313-04-030005	10,5	30	5	25
M313-04-040005	13,5	40	5	32
M313-04-050005	13,5	50	5	40
M313-04-060006	16,5	60	6	50
M313-04-080006	16,5	80	6	63
M313-04-100008	20,5	100	8	80
M313-04-120008	20,5	120	8	100
M313-04-150008	26	150	8	125

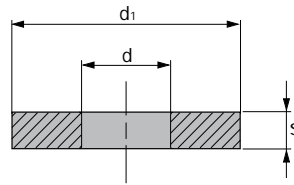
3

 Material :
 CK45

CODE	d	d ₁	s
M313-05-001	8,5	20	4
M313-05-002	10,5	25	5
M313-05-003	13,5	25	5
M313-05-004	13,2	30	5
M313-05-005	13,5	30	5
M313-05-006	12,5	32	5
M313-05-007	12,5	32	6
M313-05-008	13	32	5
M313-05-009	13,5	32	6
M313-05-010	10,5	36	5
M313-05-011	13,5	36	5
M313-05-012	16,5	36	5
M313-05-013	20,5	36	5
M313-05-014	17	38	6

CODE	d	d ₁	s
M313-05-016	20,5	45	5
M313-05-017	21	45	8
M313-05-018	10,5	55	5
M313-05-019	13,5	55	5
M313-05-020	20,5	55	5
M313-05-021	25	55	10
M313-05-022	25,5	55	5
M313-05-023	30,5	55	5
M313-05-024	12,5	60	5
M313-05-025	16,5	60	5
M313-05-026	12,5	75	5
M313-05-027	16,5	75	5
M313-05-028	16,5	90	5
M313-05-029	21	90	5
M313-05-030	21	120	5

 Material :
 CK45

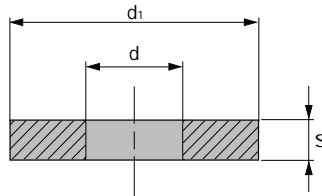
 Hardened
 HRC 45 ÷ 50

CODE	d	d ₁	s
M313-06-001	6,4	17	3
M313-06-002	8,4	23	4
M313-06-003	10,5	26	4
M313-06-004	13	30	5
M313-06-005	17	35	4
M313-06-006	17	35	5
M313-06-007	17	35	6
M313-06-008	21	42	8
M313-06-009	21	46	6
M313-06-010	25	46	10
M313-06-011	25	55	10

3

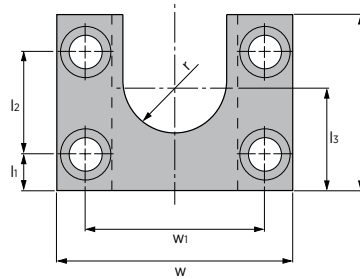
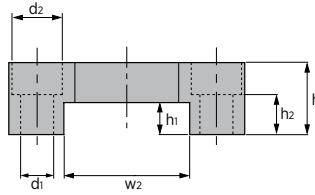
 Material :
 CK45

CODE	w	h	l	l ₁	l ₂	l ₃	w ₁	w ₂	h ₁	h ₂	d ₁	d ₂	r	Screw
M316-01-001	80	25	50	11,5	27	30	57	38	11	15	11	17	14	M10
M316-01-002	100	32	55	12,5	30	35	75	50	15	20	13	20	20	M12
M316-01-003	120	40	65	16	33	45	88	60	20	24	17	26	25	M16
M316-01-004	150	45	100	18	64	64	114	80	20	19	21	33	33	M20

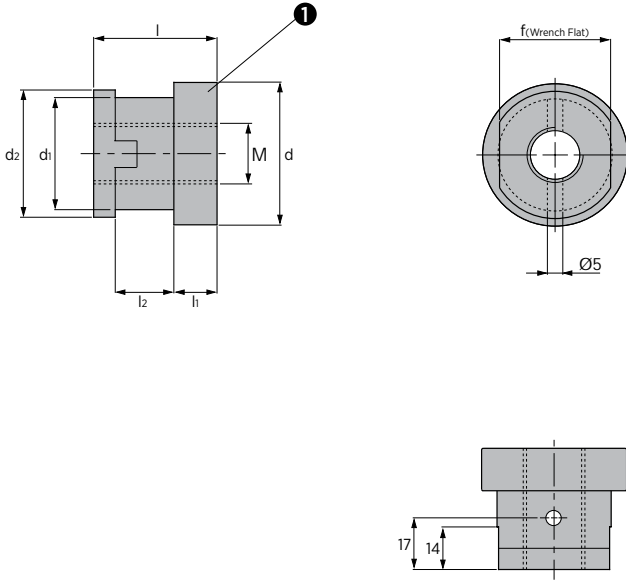

1 Material :
CK45



2 DIN EN ISO 8752

*Slotted Pin - will be supplied
with coupling nut.

3

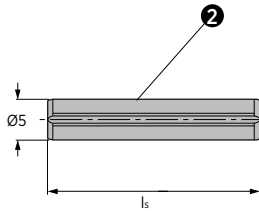

CODE	d	l	h	l ₂	l _s	d ₁	d ₂	f	M	Air Cyl. Bore Size Ø
M316-02-001	35	30	10	16	-	25	30	24	M10x1,25	32
M316-02-002	35	30	10	16	24	25	30	24	M12x1,25	40
M316-02-003	47	40	14	19	36	37	42	36	M16x1,5	50, 63
M316-02-004	47	40	14	19	36	37	42	36	M20x1,5	80, 100
M316-02-005	47	40	14	19	36	37	42	36	M27x2,0	125
M316-02-006	57	50	19	24	45	47	52	46	M36x2,0	160, 200
M316-02-007	76	76	19	50	55	59	64	60	M42x2,0	250



3

Material :
CK45

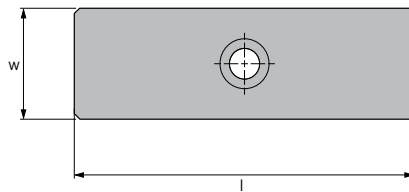
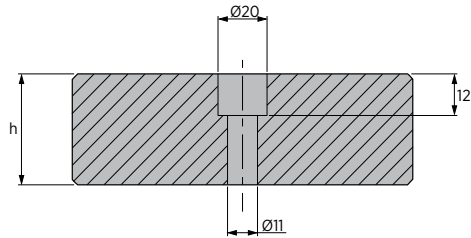

CODE	w h11	h	l
M317-04-2525080	25	25	80
M317-04-2525125	25	25	125
M317-04-3030080	30	30	80
M317-04-3030125	30	30	125

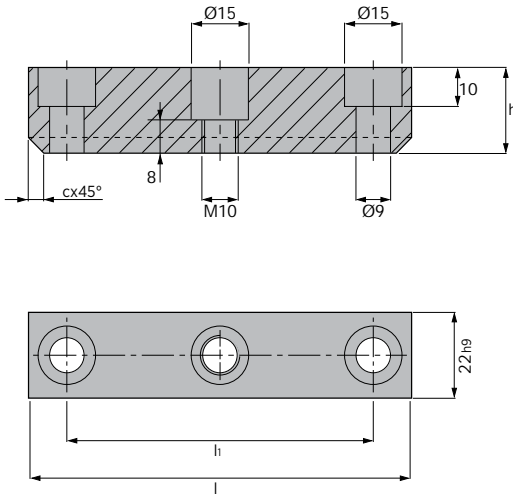

 Material :
 CK45

3

CODE	h	l	h ₉	c
M317-05-014050	14	50	32	-
M317-05-014080	14	80	50	-
M317-05-014100	14	100	80	-
M317-05-014125	14	125	100	-
M317-05-022050	22	50	32	4
M317-05-022080	22	80	50	4
M317-05-022100	22	100	80	4
M317-05-022125	22	125	100	4
M317-05-040050	40	50	32	4
M317-05-040080	40	80	50	4
M317-05-040100	40	100	80	4
M317-05-040125	40	125	100	4

3

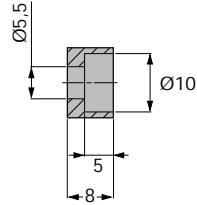
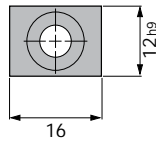
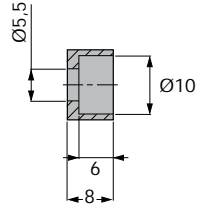
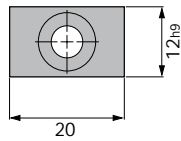
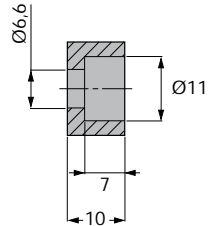
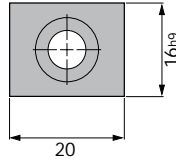
 Material :
 CK45

Form - A

Form - B

Form - C

CODE	Form
M317-07-012016	A
M317-07-012020	B
M317-07-016020	C

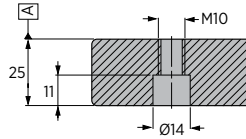
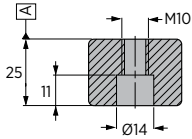
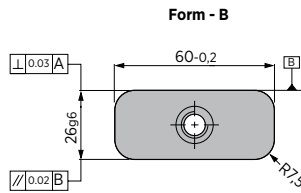
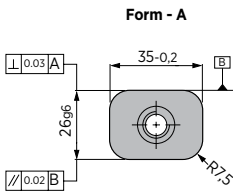
 Material :
90MnCrV8

 Hardened
HRC 58 ÷ 60

3

CODE	Form
M317-08-2635	A
M317-08-2660	B



3

Material :
CK45

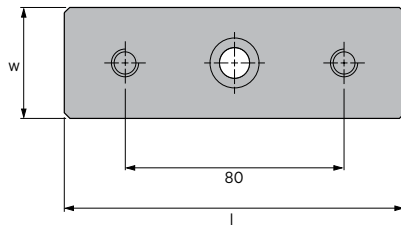
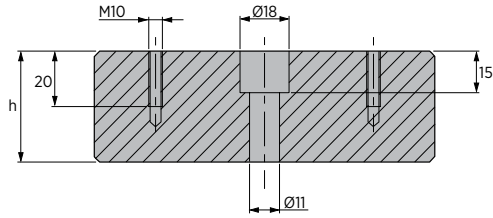

CODE	w h9	h	l
M317-10-42125	42	40	125
M317-10-50135	50	48	135
M317-10-50220	50	48	220

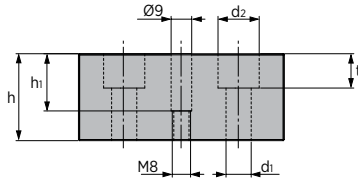
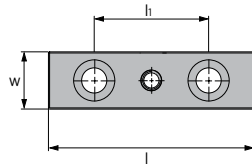
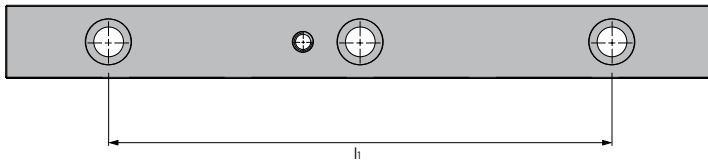

 Material :
CK45

3

Form - A

Form - B

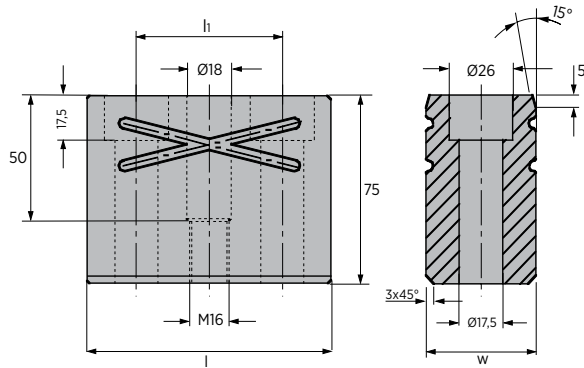
CODE	Form	w h7	h	l	l ₁	h ₁	d ₁	d ₂	t
M317-11-2538090	A	25	38	90	50	25	11	18	15
M317-11-2538120	A	25	38	120	80	25	11	18	15
M317-11-3248150	A	32	48	150	90	35	13	20	25
M317-11-3248210	A	32	48	210	130	35	13	20	25
M317-11-3258260	A	32	58	260	150	42	13	20	25
M317-11-3258310	B	32	58	310	220	42	13	20	25
M317-11-3258350	B	32	58	350	250	42	13	20	25

3

 Material :
 16MnCr5

 Hardened
 HRC 60 + 62

CODE	w h6	l	h
M317-12-045100	45	100	60
M317-12-045125	45	125	85
M317-12-045160	45	160	120
M317-12-045200	45	200	160

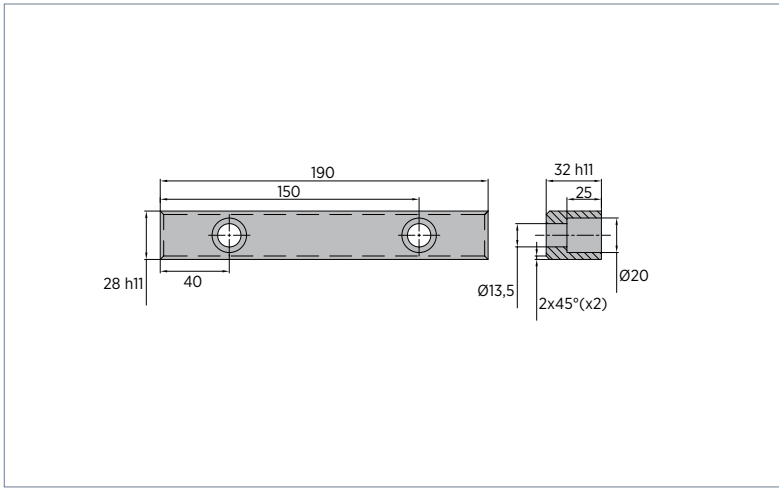
 Material :
1.0503 (C45+C)

3

CODE
M317-16-028032

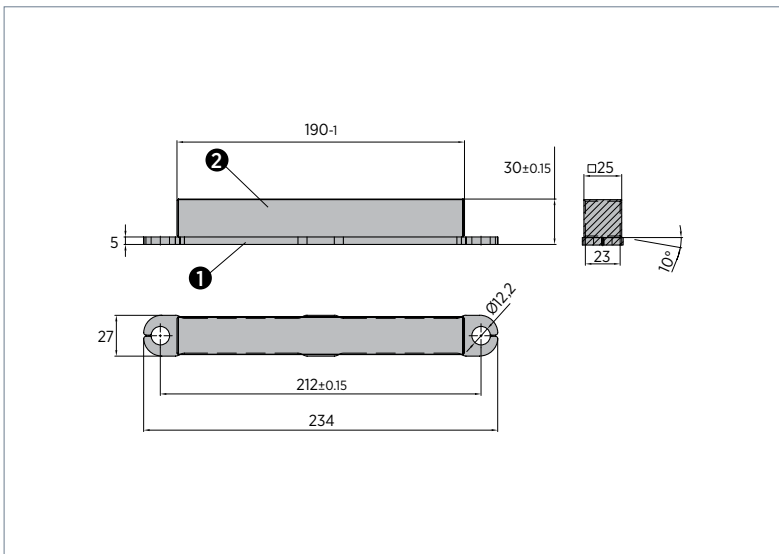
1 Material :
S355MC (t=5 mm)

2 Material :
S235 JRC+C

CODE
M317-17-025030

3

 Material :
 CK45

Screws not included.

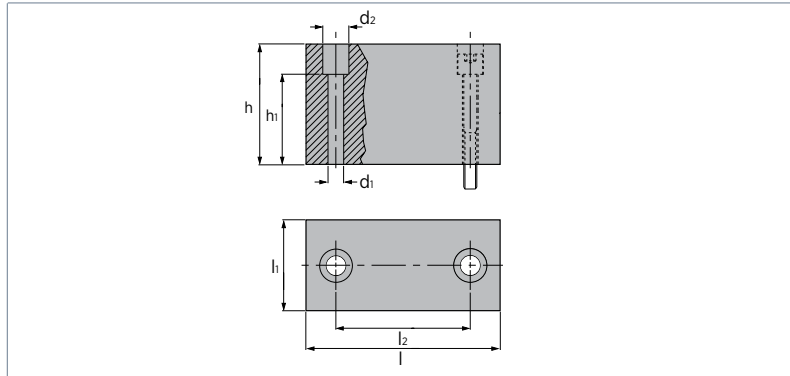

l x h	60 x 40			80 x 40			100 x 40			100 x 50			120 x 60			150 x 80		160 x 100	
d₁	9			11			14			14			14			18		18	
d₂	15			18			20			20			20			26		26	
Max. Load (t)	50			65			85			110			160			270		380	
l₂	40			56			71			76			93			120		130	
h₁	10	28	48	8	25	45	6	22	42	6	22	42	6	22	42	18	38	18	38
h±0,05																			
20	•			•															
20,3	•			•															
20,5	•			•															
23	•			•															
25	•			•			•												
28	•			•			•												
30	•			•			•			•									
30,3	•			•			•			•									
30,5	•			•			•			•									
33	•			•			•			•									
35	•			•			•			•									
38	•			•			•			•									
40	•			•			•			•			•			•			•
40,3	•			•			•			•			•			•			•
40,5	•			•			•			•			•			•			•
41	•			•			•			•			•			•			•
43	•			•			•			•			•			•			•
45	•			•			•			•			•			•			•
48	•			•			•			•			•			•			•
50	•			•			•			•			•			•			•
50,3	•			•			•			•			•			•			•
50,5	•			•			•			•			•			•			•
51	•			•			•			•			•			•			•
55	•			•			•			•			•			•			•
60	•			•			•			•			•			•			•
60,5			•			•			•			•			•			•	•
61									•			•			•			•	•

Order Example:

l= 150, h= 80, h= 40

Order Code:

M318-03-15008004000

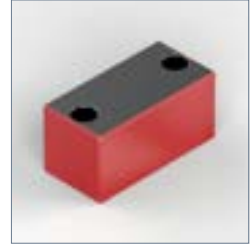
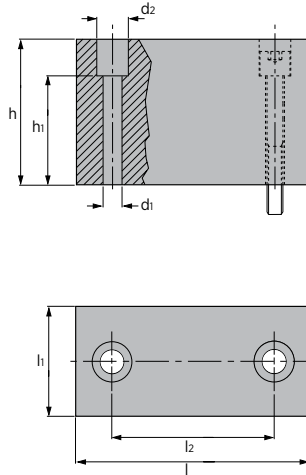
 Material :
 CK45

Screws not included.

3

CODE	l	h ₁	l ₂	d ₁	d ₂	Screw	Max. Load (t)
M318-03-???????????	60	40	40	9	15	M8	50
M318-03-???????????	80	40	56	11	18	M10	65
M318-03-???????????	100	40	71	14	20	M12	85
M318-03-???????????	100	50	76	14	20	M12	110
M318-03-???????????	120	60	93	14	20	M12	160
M318-03-???????????	150	80	120	18	26	M16	270
M318-03-???????????	160	100	130	18	26	M16	380

	M8	M10	M12	M16
h ±0,05	h ₁	h ₁	h ₁	h ₁
≥ 20 - 40	10	8	6	-
> 40 - 60	28	25	22	18
> 60 - 80	48	45	42	38
> 80 - 100	68	65	62	58
> 100 - 120	68	85	82	78
> 120 - 140	68	105	102	98
> 140 - 160	68	105	122	118

Order Example:

l= 150, h= 80, h= 85

Order Code:

M318-03-15008008500

3

 Material :
 CK45

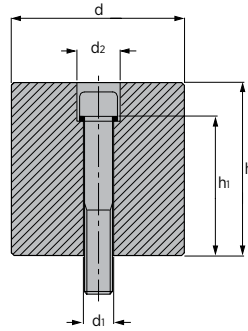

Screws not included.



d	60			80			100		120		150	
d ₁	14			18			18		22		22	
d ₂	20			26			26		33		33	
Max. Load (t)	55			100			170		250		400	
h ₁	12	22	42	20	36	20	36	15	30	15	30	
h±0,05												
25	•			•								
28	•			•								
30	•			•								
30,3	•			•								
30,5	•			•								
33	•			•								
35	•			•								
38	•			•								
40		•		•		•						
40,3		•		•		•						
40,5		•		•		•						
41		•		•		•						
43		•		•		•						
45		•		•		•						
48		•		•		•						
50		•		•		•		•			•	
50,3		•		•		•		•			•	
50,5		•		•		•		•			•	
51		•		•		•		•			•	
55		•		•		•		•			•	
60		•		•		•		•			•	
60,3			•		•		•		•		•	
60,5			•		•		•		•		•	
61			•		•		•		•		•	

Order Example:
 d= 80, h= 45

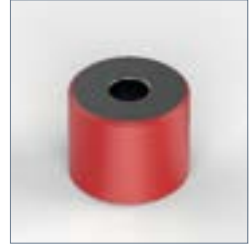
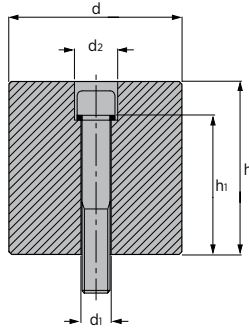
Order Code:
 M318-05-08004500

 Material :
 CK45

Screws not included.

3

CODE	d	d ₁	d ₂	Screw	Max. Load (t)
M318-05-????????	60	14	20	M12	50
M318-05-????????	80	18	26	M16	65
M318-05-????????	100	18	26	M16	85
M318-05-????????	120	22	33	M20	110
M318-05-????????	150	22	33	M20	160

	M12	M16		M20	
d	60	80	100	120	150
h ±0,05	h₁	h₁		h₁	
≥ 25 < 40	12	-	-	-	
≥ 40 - 60	22	20	20	15	
> 60 - 80	42	36	36	30	
> 80 - 100	62	56	56	50	
> 100 - 120	82	76	76	70	
> 120 - 140	102	96	96	90	
> 140 - 160	122	116	116	110	

Order Example:
 d= 80, h= 105

Order Code:
 M318-05-08010500

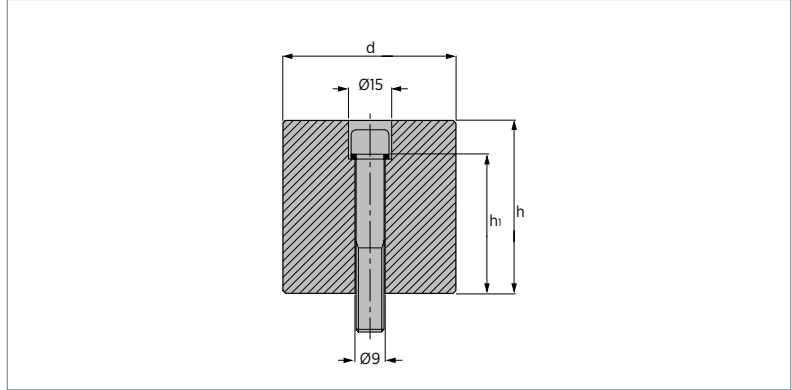

 Material :
 CK45

Screws not included.

d	25		30		40		50	
Max. Load (t)	3,5		8		20		35	
h ₁	10	28	10	28	10	28	10	28
h_{±0,05}								
20	•		•		•		•	
20,3	•		•		•		•	
20,5	•		•		•		•	
23	•		•		•		•	
25	•		•		•		•	
28	•		•		•		•	
30	•		•		•		•	
30,3	•		•		•		•	
30,5	•		•		•		•	
33	•		•		•		•	
35	•		•		•		•	
38	•		•		•		•	
40	•		•		•		•	
40,3		•		•		•		•
40,5		•		•		•		•
41				•		•		•
43				•		•		•
45				•		•		•
48				•		•		•
50				•		•		•
50,3				•		•		•
50,5				•		•		•
51						•		•
55						•		•
60						•		•
60,3						•		•
60,5						•		•

Order Example:
 d= 50, h= 45

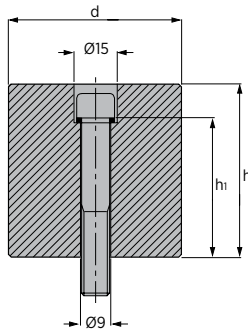
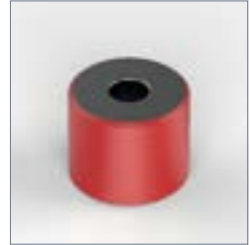
Order Code:
 M318-06-05004500

 Material :
 CK45

Screws not included.

3

CODE	d	Screw	Max. Load (t)
M318-06-????????	25	M8	3,5
M318-06-????????	30	M8	8
M318-06-????????	40	M8	20
M318-06-????????	50	M8	35

h ±0,05	h ₁
≥ 20 - 40	10
> 40 - 60	28

Order Example:
 d= 50, h= 45

Order Code:
 M318-06-05004500

3

 Material :
 42CrMo4

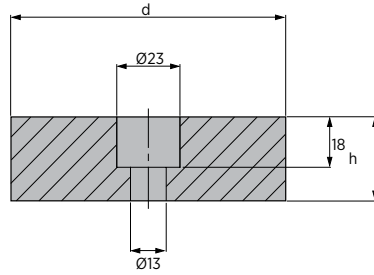
 Hardened
 HRC 46 ÷ 48

CODE	d	h
M318-07-080025	80	25
M318-07-080030	80	30
M318-07-100025	100	25
M318-07-100030	100	30
M318-07-120025	120	25
M318-07-120030	120	30

 Material :
 Steel or Brass

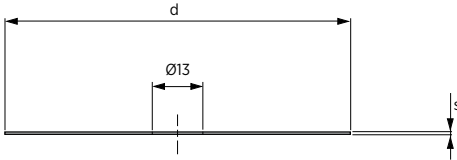
3

CODE	d	s	Material
M318-08-080001	80	0,1	Brass
M318-08-080005	80	0,5	Steel
M318-08-100001	100	0,1	Brass
M318-08-100005	100	0,5	Steel
M318-08-120001	120	0,1	Brass
M318-08-120005	120	0,5	Steel

3

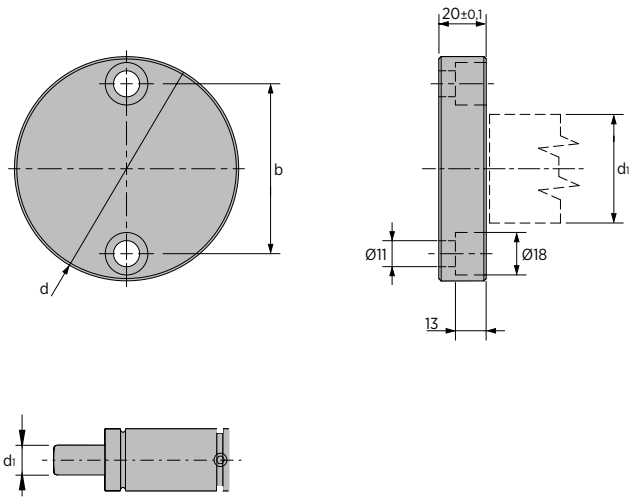
 Material :
 16MnCr5
 Hardened
 HRC 58 ÷ 60

CODE	d	d ₁	b
M318-09-065020	65	≤25	42
M318-09-095020	95	≤50	72

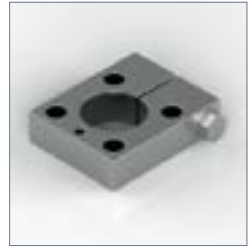
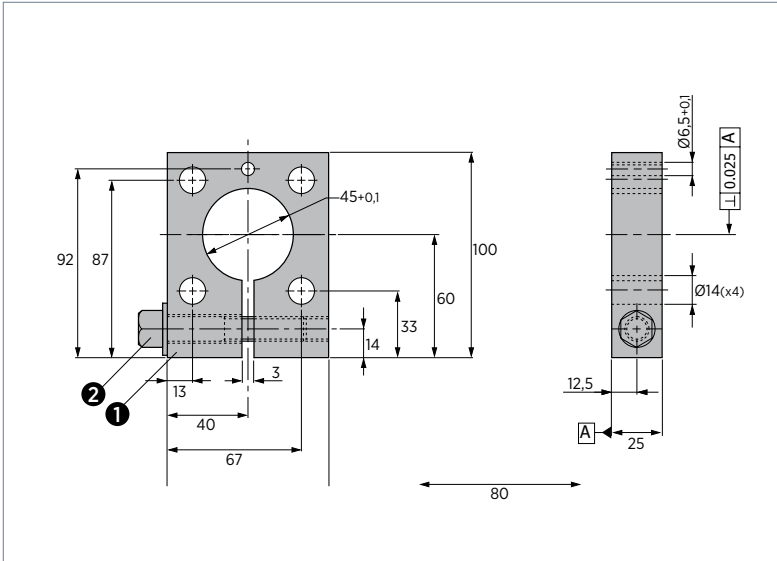

- 1 Material : CK45
- 2 M12x70 DIN 931 (8.8)

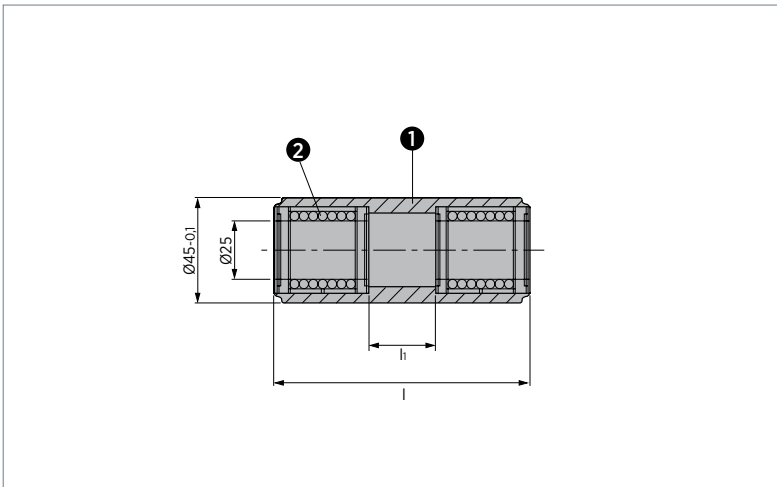

3
CODE
M319-01-100080

- 1 Material : CK45
- 2 STAR 0658-225-40

CODE	l	h
M319-01-045112	112	40
M319-01-045200	200	120

3

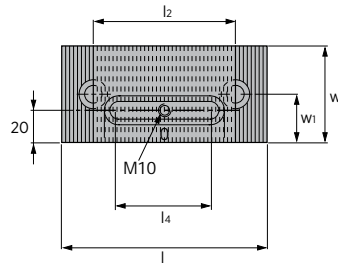
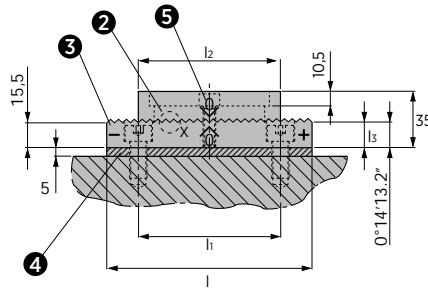
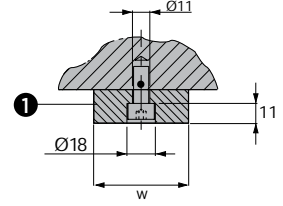
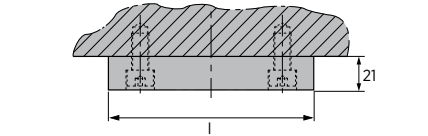
- 1 Material : 90MnCrV8
 - 2 Hardened
 - 3 HRC 58 ÷ 60
- Screws not included.
- 4 Material : X155CrVMo12
 - 5 M10x20 DIN 912



Basis : 0,02 mm per tooth

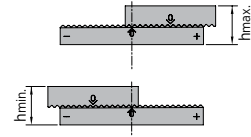

- Basic setting in the middle (grinding-in)
- + Adjustment to the right - plus
- Adjustment to the left - minus

Adjustment Range
 - 12 increments each of 0,02 mm means an adjusting range of 0,24 mm with a minimum support area of 60 x 80 mm

- 14 increments each of 0,02 mm means an adjusting range of 0,28 mm with a minimum support area of 100 x 80 mm

CODE	w	l	l ₁	l ₂	l ₃	l ₄	w ₁	h _{min.}	h _{max.}
M319-02-060130	60	130	90	90	16,04	61	30	34,88	35,12
M319-02-080160	80	160	120	110	16,16	71	40	34,86	35,14

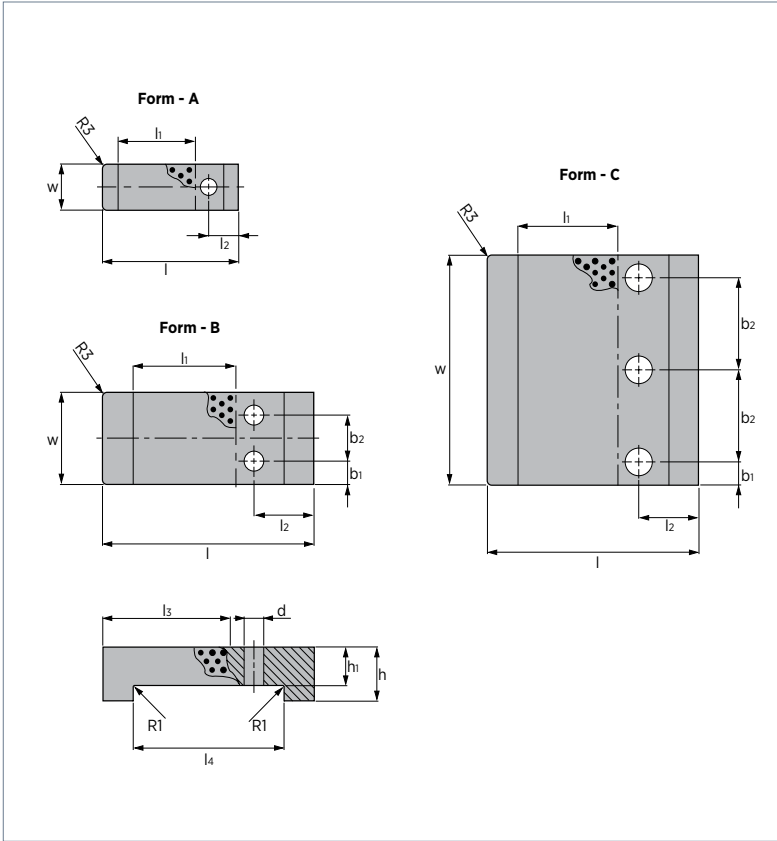
 Material :
 Bronze with
 Non-liquid Lubricant
 HB >190

3

CODE	Form	w h7	h	l	h	l ₂	l ₃	l ₄	d	h ₁	b ₁	b ₂ ±0,2
M320-03-030070	A	30	17	70	30	20	40	50	11	12	-	-
M320-03-030090	A	30	17	90	50	20	60	70	11	12	-	-
M320-03-045070	B	45	25	70	30	20	40	50	11	15	11,5	22
M320-03-045090	B	45	25	90	50	20	60	70	11	15	11,5	22
M320-03-060120	B	60	35	120	40	40	60	80	13	25	15	30
M320-03-060140	B	60	35	140	60	40	80	100	13	25	15	30
M320-03-060160	B	60	35	160	80	40	100	120	13	25	15	30
M320-03-100120	B	100	35	120	40	40	60	80	18	25	15	70
M320-03-100140	B	100	35	140	60	40	80	100	18	25	15	70
M320-03-100160	B	100	35	160	80	40	100	120	18	25	15	70
M320-03-150120	C	150	35	120	40	40	60	80	18	25	15	60
M320-03-150140	C	150	35	140	60	40	80	100	18	25	15	60
M320-03-150160	C	150	35	160	80	40	100	120	18	25	15	60
M320-03-150180	C	150	35	180	100	40	120	140	18	25	15	60

3

 Material :
 CK45

 Hardened
 HRC 52 ÷ 54

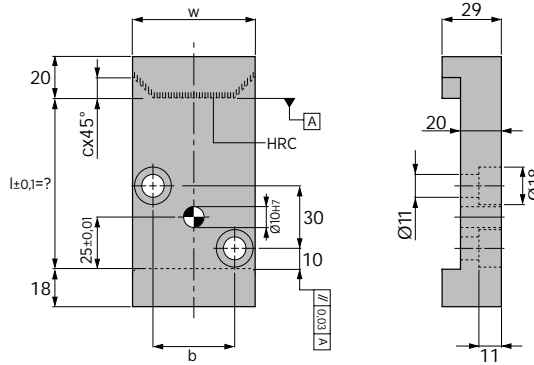
 Length (l) is given by the
 customer.

CODE	w -l	b	c
M320-07-035-l	35	15	7
M320-07-060-l	60	40	10

Order Example:
 w= 35, l= 110

Order Code:
 M320-07-035110

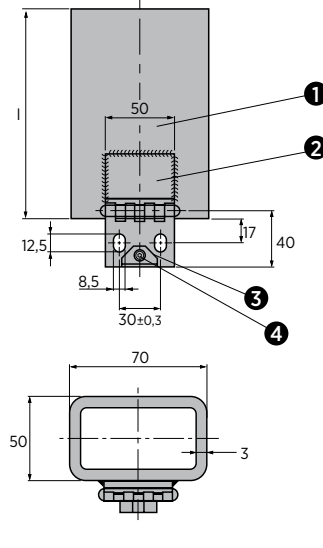

- 1 Material :
St 37
- 2 Hinge
- 3 Material :
Elastomer 68 Shore
- 4 Screw M4x8 DIN 912

3

CODE	l±0,05	Max. Load (kN)
M321-01-070065	65	125
M321-01-070070	70	125
M321-01-070075	75	125
M321-01-070080	80	125
M321-01-070085	85	125
M321-01-070090	90	125
M321-01-070095	95	125
M321-01-070100	100	125
M321-01-070105	105	125
M321-01-070110	110	125
M321-01-070115	115	125
M321-01-070120	120	125
M321-01-070125	125	125
M321-01-070130	130	125
M321-01-070135	135	125
M321-01-070140	140	125
M321-01-070145	145	125
M321-01-070150	150	125
M321-01-070155	155	125
M321-01-070160	160	125
M321-01-070165	165	125
M321-01-070170	170	125
M321-01-070175	175	125
M321-01-070180	180	125
M321-01-070185	185	125

CODE	l±0,05	Max. Load (kN)
M321-01-070190	190	125
M321-01-070195	195	125
M321-01-070200	200	125
M321-01-070205	205	125
M321-01-070210	210	125
M321-01-070215	215	125
M321-01-070220	220	125
M321-01-070225	225	125
M321-01-070230	230	125
M321-01-070235	235	125
M321-01-070240	240	125
M321-01-070245	245	125
M321-01-070250	250	125
M321-01-070260	260	125
M321-01-070270	270	125
M321-01-070280	280	125
M321-01-070290	290	125
M321-01-070300	300	125
M321-01-070310	310	125
M321-01-070320	320	125
M321-01-070330	330	125
M321-01-070340	340	125
M321-01-070350	350	125

3

- 1 Material :
St 37
- 2 Hinge
- 3 Material :
Elastomer 68 Shore
- 4 Screw M4x8 DIN 912



Length (l) is given by the customer;

Max. Length: 365 mm

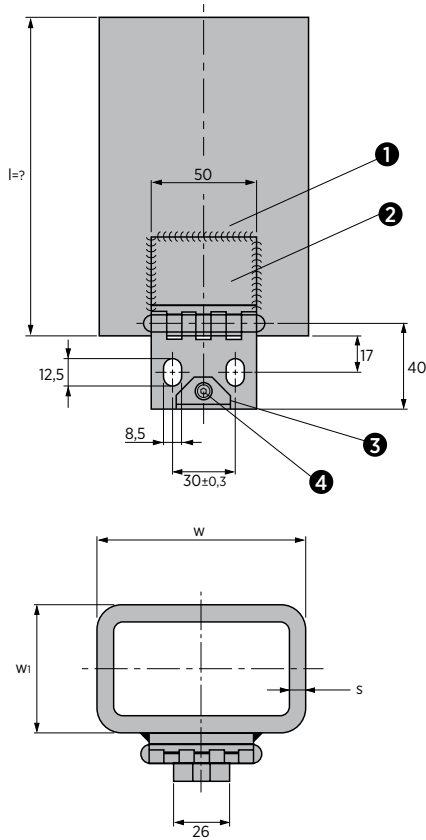

CODE	w	w ₁	s	Max. Load (kN)
M321-01-070-l	70	50	3	125
M321-01-100-l	100	60	8	250

Order Example:
w= 100, l= 200

Order Code:
M321-01-100200

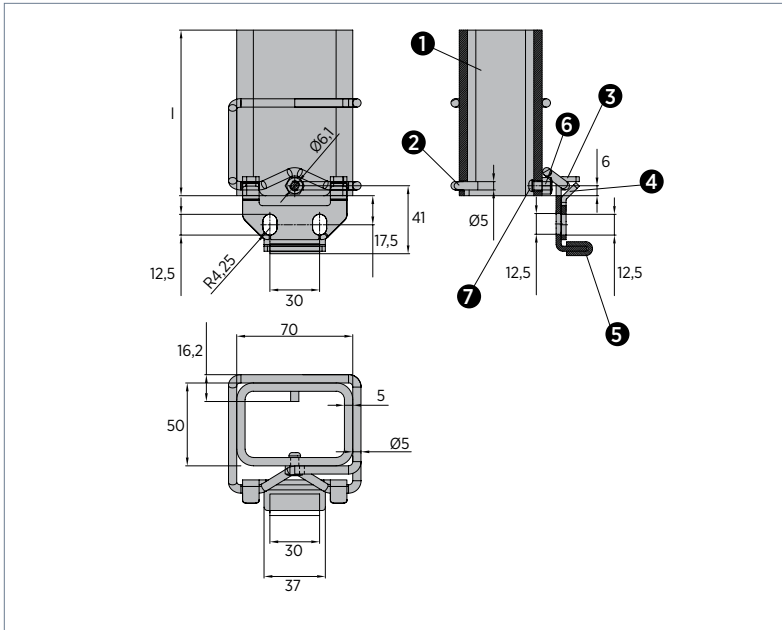

- 1** Material : S235JR
- 2** Material : 1.4310
- 3** Material : S235/DC01
- 4**
- 5** Material : Soft-PVC
- 6** Material : M6 DIN 934
- 7** Material : Rivet Ø5x14 DIN 7337



3

CODE	l±0,05	Max. Load (kN)
M321-02-070065	65	235
M321-02-070070	70	235
M321-02-070075	75	235
M321-02-070080	80	235
M321-02-070085	85	235
M321-02-070090	90	235
M321-02-070095	95	235
M321-02-070100	100	235
M321-02-070105	105	235
M321-02-070110	110	235
M321-02-070115	115	235
M321-02-070120	120	235
M321-02-070125	125	235
M321-02-070130	130	235
M321-02-070135	135	235
M321-02-070140	140	235
M321-02-070145	145	235
M321-02-070150	150	235
M321-02-070155	155	235
M321-02-070160	160	235
M321-02-070165	165	235
M321-02-070170	170	235
M321-02-070175	175	235
M321-02-070180	180	235

CODE	l±0,05	Max. Load (kN)
M321-02-070185	185	235
M321-02-070190	190	235
M321-02-070195	195	235
M321-02-070200	200	235
M321-02-070205	205	235
M321-02-070210	210	235
M321-02-070215	215	235
M321-02-070220	220	235
M321-02-070225	225	235
M321-02-070230	230	235
M321-02-070235	235	235
M321-02-070240	240	235
M321-02-070245	245	235
M321-02-070250	250	235
M321-02-070260	260	235
M321-02-070270	270	235
M321-02-070280	280	235
M321-02-070290	290	235
M321-02-070300	300	235
M321-02-070310	310	235
M321-02-070320	320	235
M321-02-070330	330	235
M321-02-070340	340	235
M321-02-070350	350	235

3

- 1** Material : S235JR
- 2** Material : 1.4310
- 3** Material : S235/DC01
- 4**
- 5** Material : Soft-PVC
- 6** Material : M6 DIN 934
- 7** Material : Rivet Ø5x12 DIN 7337

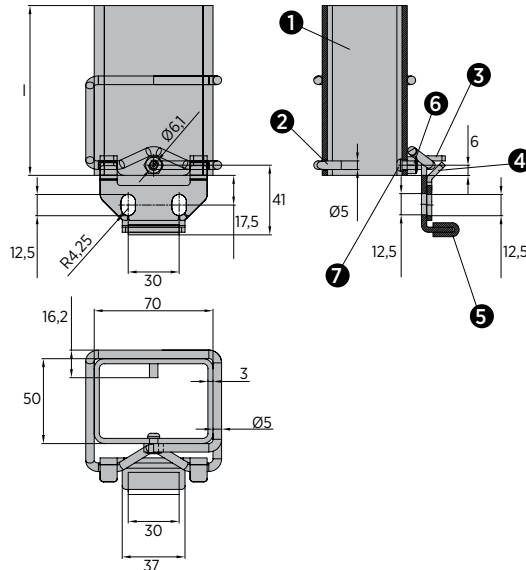

CODE	±0,05	Max. Load (kN)
M321-03-080065	65	125
M321-03-080070	70	125
M321-03-080075	75	125
M321-03-080080	80	125
M321-03-080085	85	125
M321-03-080090	90	125
M321-03-080095	95	125
M321-03-080100	100	125
M321-03-080105	105	125
M321-03-080110	110	125
M321-03-080115	115	125
M321-03-080120	120	125
M321-03-080125	125	125
M321-03-080130	130	125
M321-03-080135	135	125
M321-03-080140	140	125
M321-03-080145	145	125
M321-03-080150	150	125
M321-03-080155	155	125
M321-03-080160	160	125
M321-03-080165	165	125
M321-03-080170	170	125
M321-03-080175	175	125
M321-03-080180	180	125

CODE	±0,05	Max. Load (kN)
M321-03-080185	185	125
M321-03-080190	190	125
M321-03-080195	195	125
M321-03-080200	200	125
M321-03-080205	205	125
M321-03-080210	210	125
M321-03-080215	215	125
M321-03-080220	220	125
M321-03-080225	225	125
M321-03-080230	230	125
M321-03-080235	235	125
M321-03-080240	240	125
M321-03-080245	245	125
M321-03-080250	250	125
M321-03-080260	260	125
M321-03-080270	270	125
M321-03-080280	280	125
M321-03-080290	290	125
M321-03-080300	300	125
M321-03-080310	310	125
M321-03-080320	320	125
M321-03-080330	330	125
M321-03-080340	340	125
M321-03-080350	350	125

 Material:
 S235JR

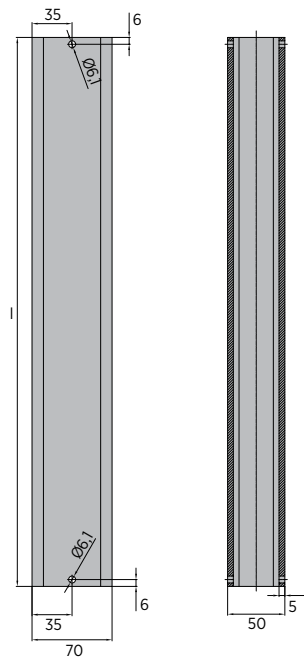
3

CODE	l ± 0,05
M321-04-071	480

3



Material:
S235JR

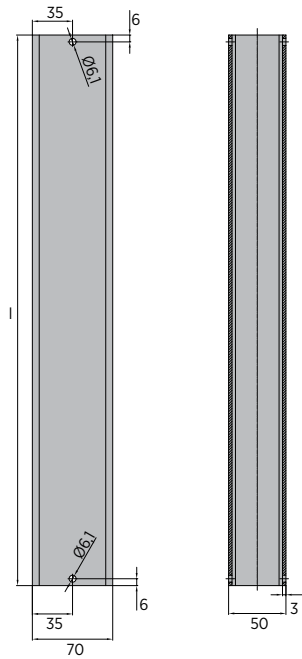

CODE	l±0,05
M321-04-081	480

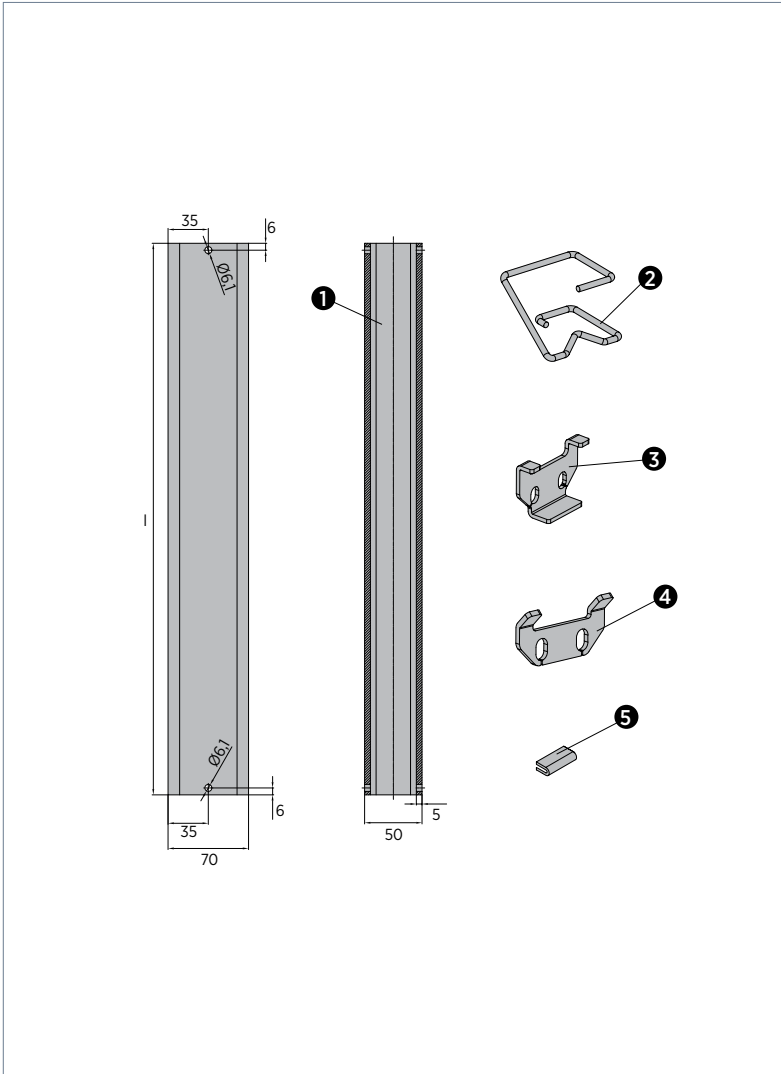

- 1** Material : S235JR
- 2** Material : 1.4310
- 3** Material : S235/DC01
- 4** Material : S235/DC01
- 5** Material : Soft-PVC



CODE		
	M321-05-75 Set	
1	M321-04-071	50 adet / pcs
2	M321-02/15	100 adet / pcs
3	M321-02/16	100 adet / pcs
4	M321-02/17	100 adet / pcs
5	M321-02/18	4 metre / meter

3

- 1** Material : S235JR
- 2** Material : 1.4310
- 3** Material : S235/DC01
- 4** Material : S235/DC01
- 5** Material : Soft-PVC

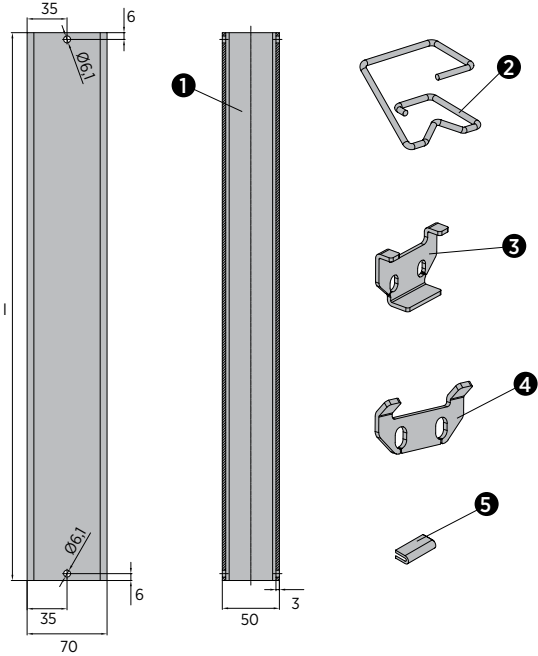

CODE		
	M321-05-85 Set	
1	M321-04-081	50 adet / pcs
2	M321-02/15	100 adet / pcs
3	M321-02/16	100 adet / pcs
4	M321-02/17	100 adet / pcs
5	M321-02/18	4 metre / meter

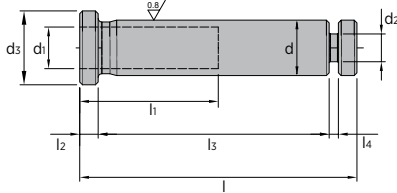
 Material :
 16MnCr5
 Hardened
 HRC 60



CODE	d h6	l -0,5	h	l ₂	l ₃ ±0,1	l ₄	d ₁	d ₂ -0,05/-0,1	d ₃ -0,2/-0,5
M322-01-0060295	6	29,5	-	2	25	0,5	-	3	8
M322-01-006030	6	30	-	2	25	1	-	3	8
M322-01-0060365	6	36,5	-	2	32	0,5	-	3	8
M322-01-006037	6	37	-	2	32	1	-	3	8
M322-01-008031	8	31	-	3	25	1	-	5	10
M322-01-008032	8	32	-	3	25	2	-	5	10
M322-01-008038	8	38	-	3	32	1	-	5	10
M322-01-008039	8	39	-	3	32	2	-	5	10
M322-01-008046	8	46	-	3	40	1	-	5	10
M322-01-008047	8	47	-	3	40	2	-	5	10
M322-01-010033	10	33	18	3	25	2	6,5	6	12,5
M322-01-010034	10	34	18	3	25	3	6,5	6	12,5
M322-01-010040	10	40	24	3	32	2	6,5	6	12,5
M322-01-010041	10	41	24	3	32	3	6,5	6	12,5
M322-01-010048	10	48	30	3	40	2	6,5	6	12,5
M322-01-010049	10	49	30	3	40	3	6,5	6	12,5
M322-01-012033	12	33	18	3	25	2	8,5	7	16
M322-01-012034	12	34	18	3	25	3	8,5	7	16
M322-01-012040	12	40	24	3	32	2	8,5	7	16
M322-01-012041	12	41	24	3	32	3	8,5	7	16
M322-01-012048	12	48	30	3	40	2	8,5	7	16
M322-01-012049	12	49	30	3	40	3	8,5	7	16
M322-01-016042	16	42	24	3	32	3	10,5	7	20
M322-01-016044	16	44	24	3	32	5	10,5	8	20
M322-01-016050	16	50	30	3	40	3	10,5	8	20
M322-01-016052	16	52	30	3	40	5	10,5	8	20
M322-01-016060	16	60	40	3	50	3	10,5	8	20
M322-01-016062	16	62	40	3	50	5	10,5	8	20
M322-01-020052	20	52	30	5	40	3	12,5	12	25
M322-01-020054	20	54	30	5	40	5	12,5	12	25
M322-01-020062	20	62	40	5	50	3	12,5	12	25
M322-01-020064	20	64	40	5	50	5	12,5	12	25
M322-01-020075	20	75	50	5	63	3	12,5	12	25
M322-01-020077	20	77	50	5	63	5	12,5	12	25

3

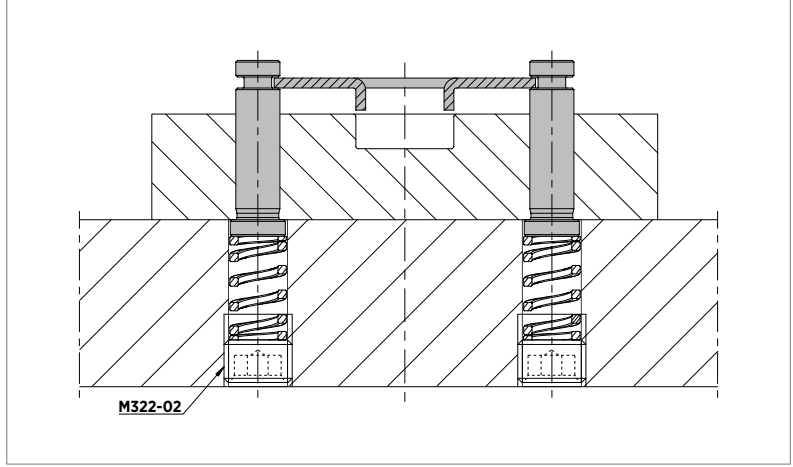
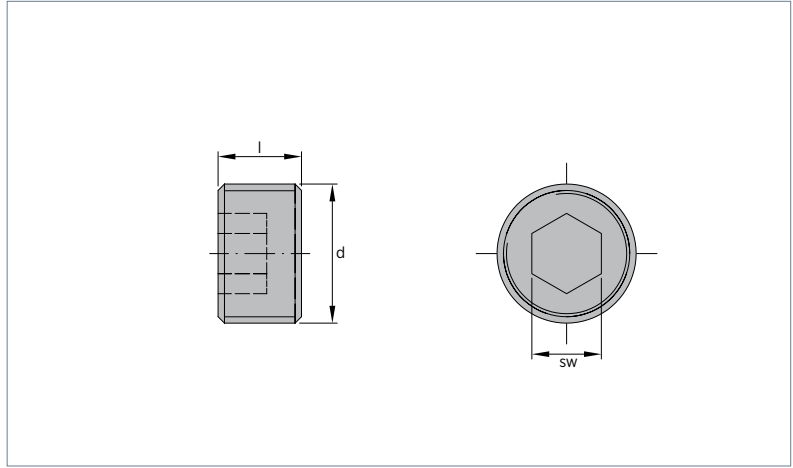
 Material :
 16MnCr5

 Hardened
 HRC 60

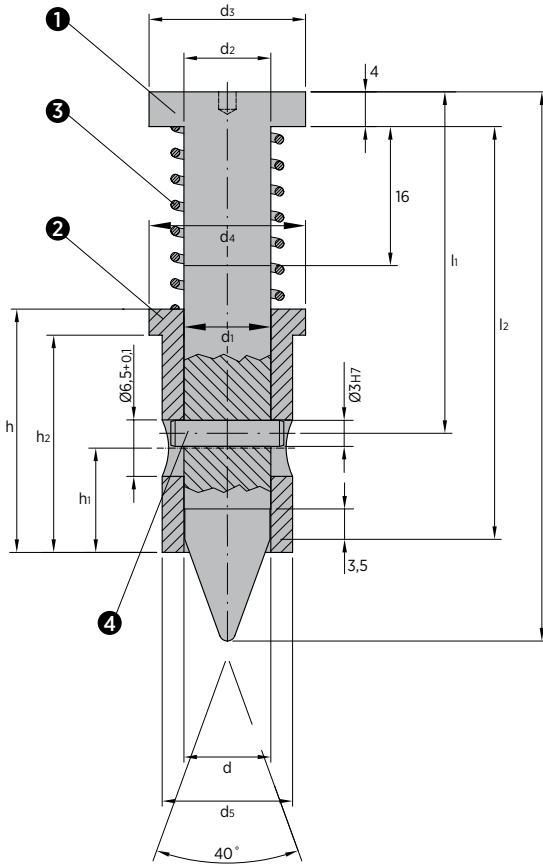
 Material :
 Steel 12.9

CODE	d	l	SW
M322-02-12010	M12x1,5	10	6
M322-02-14010	M14x1,5	10	6
M322-02-16010	M16x1,5	10	8
M322-02-18010	M18x1,5	10	10
M322-02-20012	M20x1,5	12	10
M322-02-22012	M22x1,5	12	12
M322-02-24012	M24x1,5	12	14
M322-02-27012	M27x1,5	12	14
M322-02-36012	M36x1,5	12	17

3

1 Punch 1.2550

 Hardness
 50 ± 2 HRC

2 Bush 1.3505

 Hardness
 58 ± 2 HRC

3 Coil Spring

4 Ø3x14 DIN 6325

CODE	d +0,05	l	h ₁	h ₂	l ₂	d ₁ H7, f7	d ₂	d ₃	d ₄	d ₅ f7	h	h ₁	h ₂ +0,1	Spring force preloaded (daN)	Spring force pressed (daN)
M323-01-0980632	9,8	63,2	39,3	47,5	10	10	18	18	15	28	12	25	4,9	6,2	
M323-01-1580725	15,8	72,5	46,3	54,5	16	16	24	30	26	28	12	25	4,8	5,6	

3

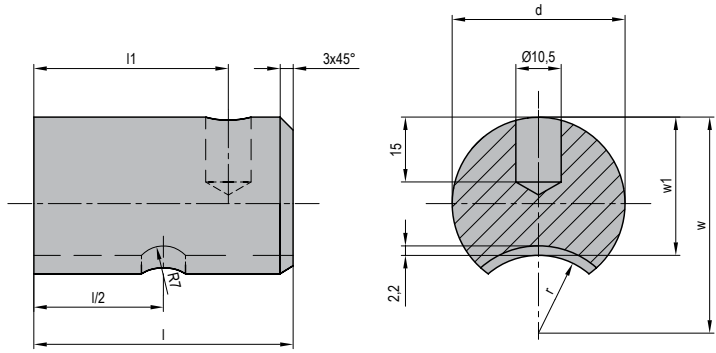
 Material :
 Elastomer 92 Sh

CODE	d ±0,25	w	l	l1	l/2	w1	r
S510-02-040060	40	50	60	45	30	32	18
S510-02-050080	50	63	80	60	40	40	23
S510-02-063080	63	86	80	60	40	51	35

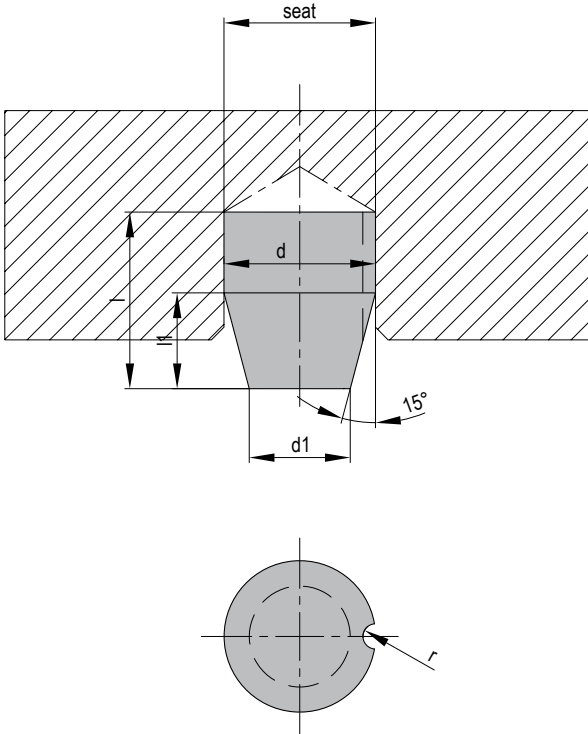
 Material :
 Elastomer 92 Shore

3

CODE	d +0,3 / +0,5	l	h	d ₁	r	seat ±0,1	F max. (N)
S511-01-006	6	9,5	4,5	3,6	-	6	100
S511-01-010	10	15,5	7,5	6	1	10	450
S511-01-016	16	25	12	9,5	1,5	16	1500
S511-01-024	24	25	10	18	2	24	3000
S511-01-030	30	35	19	20	2,5	30	3000
S511-01-032	32	32	14	24	3	32	12000
S511-01-039	39,5	40	16	30	3	39,5	25000

3

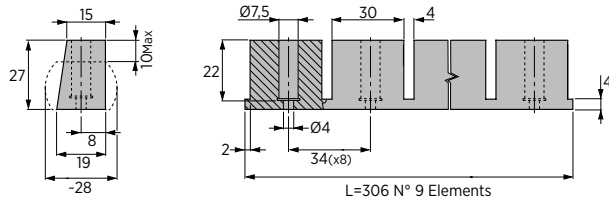
 Material :
 Elastomer 70 Shore

CODE
S515-03-0017

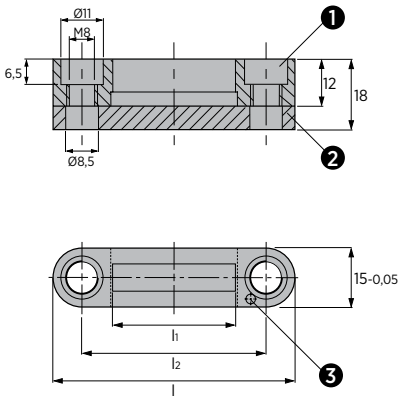

3



1 Material :
CK45



3 ELASTIC PIN Ø2.5x14
DIN 1481

CODE	l -0,05	h +0,1	l ₂	Number of Stamps
Z401-01-045	45	12	30	6
Z401-01-047	47	16	32	8
Z401-01-055	55	24	40	12
Z401-01-063	63	32	48	16
Z401-01-071	71	40	56	20

3

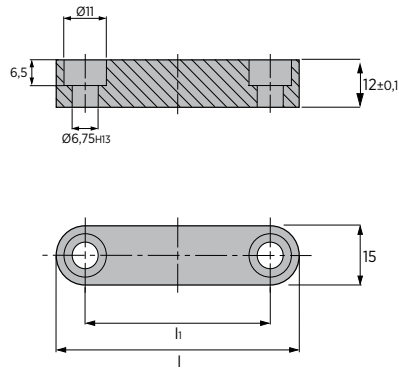
 Material :
 CK45

CODE	l	h
Z401-02-045	45	30
Z401-02-047	47	32
Z401-02-056	55	40
Z401-02-063	63	48
Z401-02-071	71	56



Material :
X153CrMoV12
Hardened
HRC 54 ÷ 56

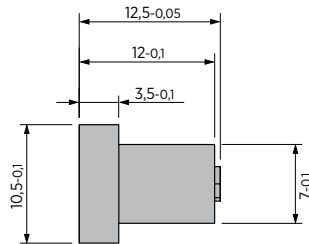
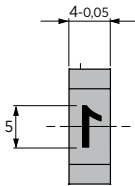

CODE	Stamp
Z401-06-000	0
Z401-06-001	1
Z401-06-002	2
Z401-06-003	3
Z401-06-004	4
Z401-06-005	5
Z401-06-006	6 or 9
Z401-06-007	7
Z401-06-008	8
Z401-06-009	A
Z401-06-010	B
Z401-06-011	C
Z401-06-012	D

CODE	Stamp
Z401-06-013	E
Z401-06-014	F
Z401-06-015	G
Z401-06-016	H
Z401-06-017	I
Z401-06-018	J
Z401-06-019	K
Z401-06-020	L
Z401-06-021	M
Z401-06-022	N
Z401-06-023	O
Z401-06-024	P
Z401-06-025	Q

CODE	Stamp
Z401-06-026	R
Z401-06-027	S
Z401-06-028	T
Z401-06-029	U
Z401-06-030	V
Z401-06-031	W
Z401-06-032	X
Z401-06-033	Y
Z401-06-034	Z
Z401-06-035	Space
Z401-06-036	-
Z401-06-037	_

3

 Material :
 X153CrMoV12

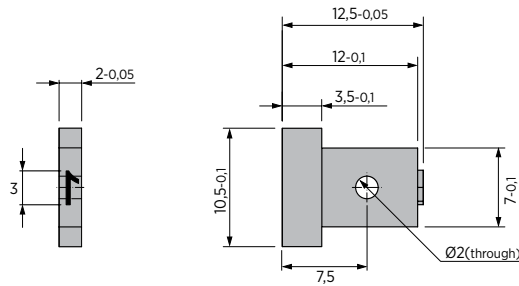
 Hardened
 HRC 54 ÷ 56

CODE	Stamp
Z401-07-000	0
Z401-07-001	1
Z401-07-002	2
Z401-07-003	3
Z401-07-004	4
Z401-07-005	5
Z401-07-006	6 or 9
Z401-07-007	7
Z401-07-008	8
Z401-07-009	A
Z401-07-010	B
Z401-07-011	C
Z401-07-012	D

CODE	Stamp
Z401-07-013	E
Z401-07-014	F
Z401-07-015	G
Z401-07-016	H
Z401-07-017	I
Z401-07-018	J
Z401-07-019	K
Z401-07-020	L
Z401-07-021	M
Z401-07-022	N
Z401-07-023	O
Z401-07-024	P
Z401-07-025	Q

CODE	Stamp
Z401-07-026	R
Z401-07-027	S
Z401-07-028	T
Z401-07-029	U
Z401-07-030	V
Z401-07-031	W
Z401-07-032	X
Z401-07-033	Y
Z401-07-034	Z
Z401-07-035	Space
Z401-07-036	-
Z401-07-037	_



3

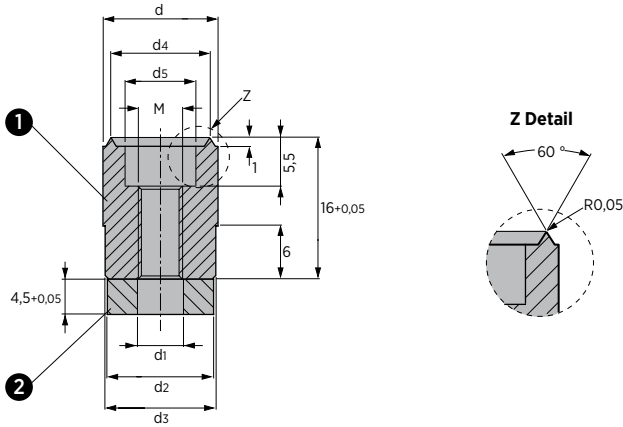

1 Material :
X205Cr12KU
Hardened
HRC 60 ÷ 62



2 Material: X205Cr12KU

CODE	d d9	d ₁	d ₂	d ₃	d ₄ ±0,1	d ₅	M
Z402-03-010	10	4,2	9,9	9,5	8	6	M4
Z402-03-013	13	5,2	12	12,5	11,2	8	M5

3

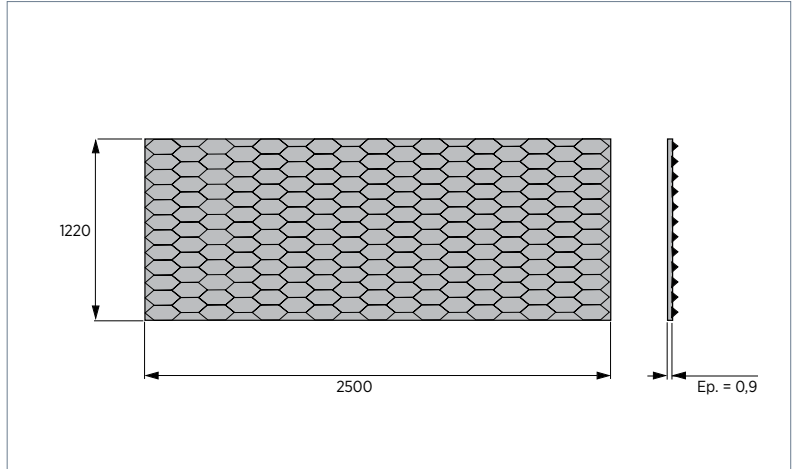

Material :
Stainless Steel



CODE	Dimensions mm
Z000166439	2500x1220xep.0,9

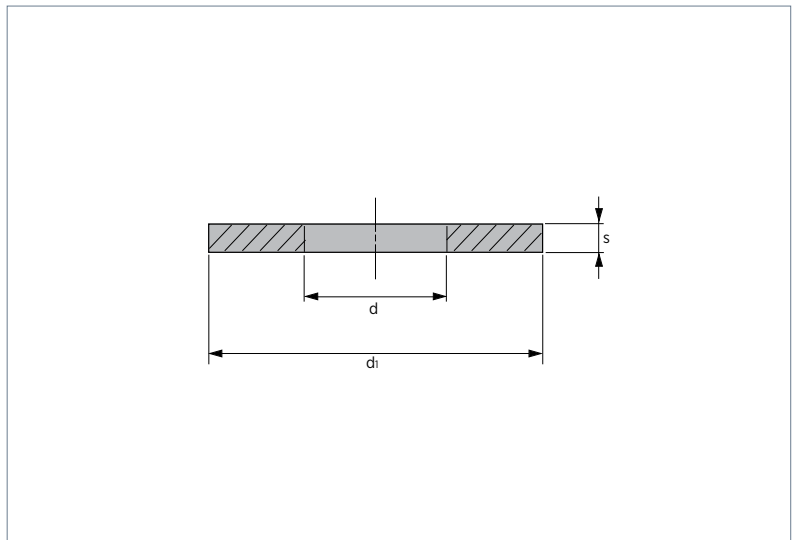

Material :
CK45

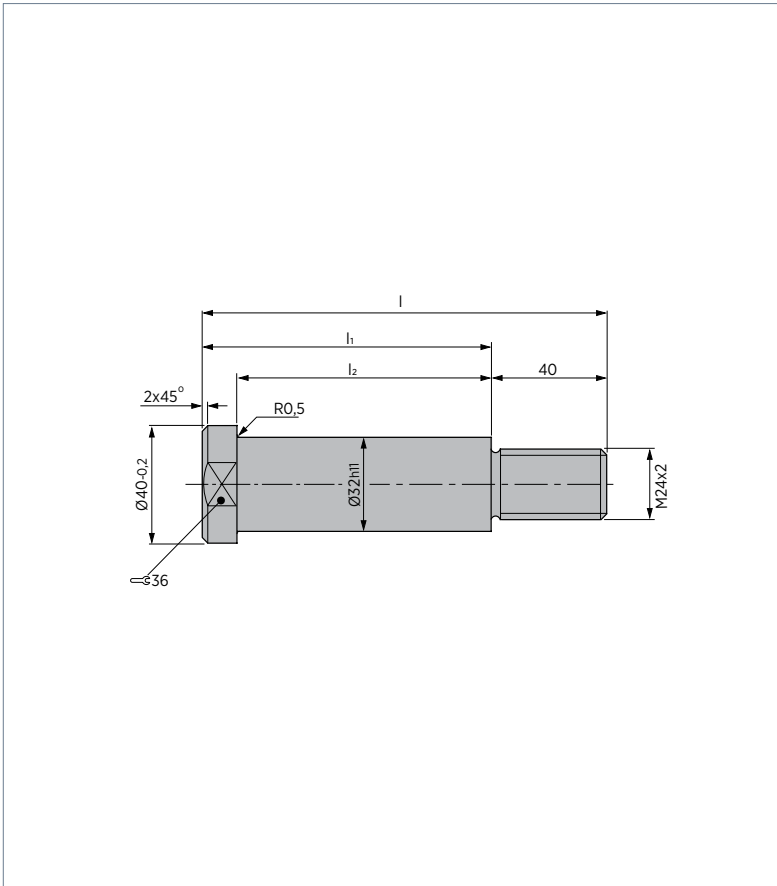

CODE	d	d ₁	s
A101-15-001	33	80	6
A101-15-002	33	100	8

 Material :
 42CrMo4
 1000 ÷ 1200 N/mm²

3

CODE	l	l ₁	l ₂
M307-04-048	100	60	48
M307-04-068	120	80	68
M307-04-088	140	100	88
M307-04-108	160	120	108
M307-04-128	180	140	128
M307-04-148	200	160	148
M307-04-168	220	180	168
M307-04-188	240	200	188
M307-04-208	260	220	208
M307-04-228	280	240	228
M307-04-248	300	260	248
M307-04-268	320	280	268
M307-04-288	340	300	288

3

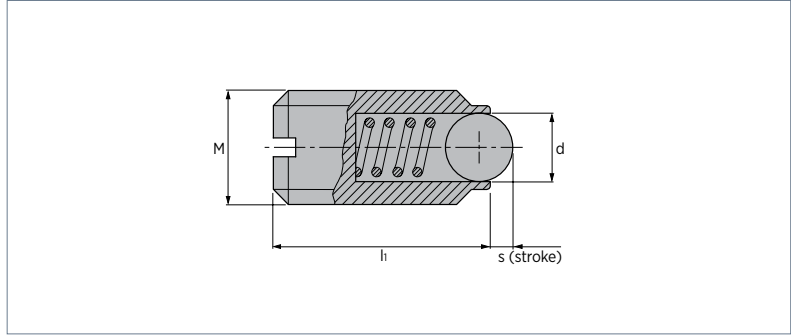
 Material :
 Steel Class 5.8
 Hardened inox.

CODE	d	h	s	M	Initial Force (N)	Final Force (N)
M314-01-004	2.5	9	0.8	M4	6	12
M314-01-005	3	12	0.9	M5	7	13
M314-01-006	3.5	14	1.0	M6	9	15
M314-01-008	5	16	1.5	M8	20	35
M314-01-010	6	19	2.0	M10	25	45
M314-01-012	8	22	2.5	M12	35	60
M314-01-016	10	24	3.5	M16	65	110

 Material :
 C80W2

 Hardened
 HRC 36 ÷ 40

Body 34CrMo4

Springs C80W2

 Hardened
 HRC 36 ÷ 40

Black oxide finish.

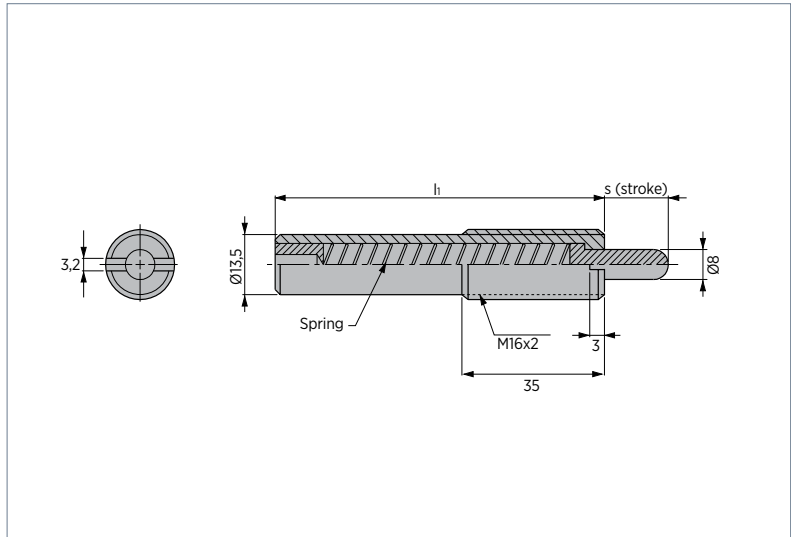

CODE	l ₁	s	Initial Force (N)	Final Force (N)
M314-02-060	150	60	11	45
M314-02-080	200	80	2	38

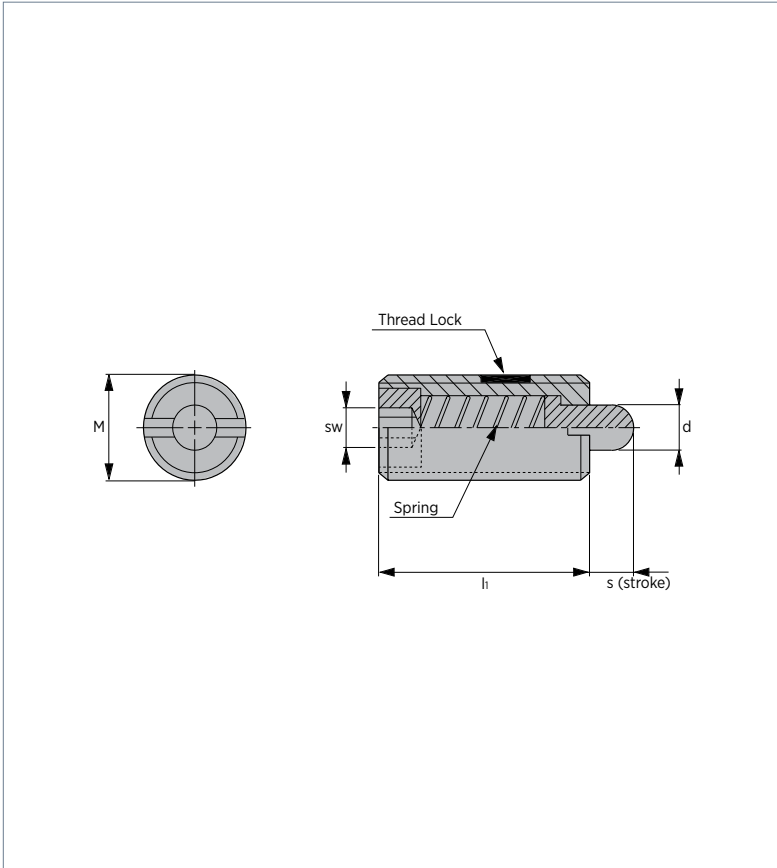

Material :
90Mn4

Hardened
HRC 36 ÷ 40

Body 34CrMo4

Black oxide finish.



3

CODE	d	h	s	sw	M	Initial Force N (Kgf)	Final Force N (Kgf)
M314-03-001	1	10	1,5	0,8	M3x0,5	0,4 (0,05)	2,9 (0,3)
M314-03-002	1,6	12	2	0,8	M4x0,7	1,9 (0,2)	9,8 (1,0)
M314-03-003	2	20	3	1,5	M5x0,8	3,9 (0,4)	19,6 (2,0)
M314-03-004	2	13	3	1,5	M5x0,8	1,9 (0,2)	7,8 (0,8)
M314-03-005	2	20	3	1,5	M5x0,8	1,9 (0,2)	9,8 (1,0)
M314-03-006	2,5	25	3	2,0	M6x1,0	2,9 (0,3)	9,8 (1,0)
M314-03-007	2,5	25	3	2,0	M6x1,0	7,8 (0,8)	29,4 (3,0)
M314-03-008	3,1	25	3	2,5	M8x1,25	2,9 (0,3)	9,8 (1,0)
M314-03-009	3,1	25	3	2,5	M8x1,25	7,8 (0,8)	29,4 (3,0)
M314-03-010	3,8	30	5	3,0	M10x1,5	2,9 (0,3)	14,7 (1,5)
M314-03-011	3,8	30	5	3,0	M10x1,5	9,8 (1,0)	49,0 (5,0)
M314-03-012	5,5	30	5	4,0	M12x1,75	1,9 (0,2)	9,8 (1,0)
M314-03-013	5,5	30	5	4,0	M12x1,75	9,8 (1,0)	49,0 (5,0)

3

Material :
Pin 90Mn4

Hardened
HRC 36 ÷ 40

Body 34CrMo4

Black oxide finish.

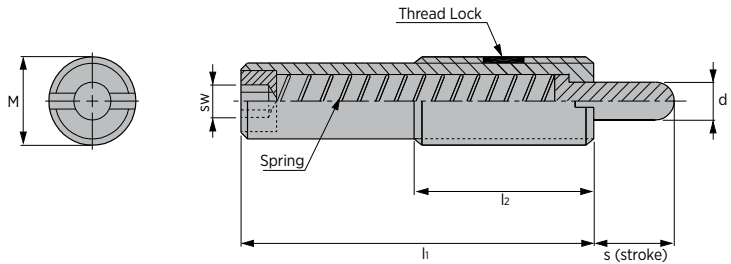

CODE	d	h	l ₂	s	sw	M	Initial Force N (Kgf)	Final Force N (Kgf)
M314-04-001	5,5	43	35	10	4	M12x1,75	3,9 (0,4)	19,6 (2)
M314-04-002	5,5	43	35	10	4	M12x1,75	6,8 (0,7)	39,2 (4)
M314-04-003	8	50	35	10	5	M16x2,0	9,8 (1)	49,0 (5)
M314-04-004	8	50	35	10	5	M16x2,0	19,6 (2)	98,0 (10)
M314-04-005	8	60	35	10	5	M16x2,0	12,7 (1,3)	39,2 (4)
M314-04-006	8	60	35	10	5	M16x2,0	26,4 (2,7)	78,4 (8)
M314-04-007	8	60	35	15	5	M16x2,0	9,8 (1)	39,2 (4)
M314-04-008	8	60	35	15	5	M16x2,0	14,7 (1,5)	78,4 (8)
M314-04-009	8	85	35	20	5	M16x2,0	12,7 (1,3)	39,2 (4)
M314-04-010	8	85	35	20	5	M16x2,0	16,6 (1,7)	78,4 (8)
M314-04-011	8	125	35	30	5	M16x2,0	19,6 (1,8)	78,4 (4)
M314-04-012	8	125	35	30	5	M16x2,0	19,6 (2)	78,4 (8)
M314-04-013	8	155	35	50	8	M16x2,0	19,6 (2)	49,0 (5)
M314-04-014	8	155	35	50	8	M16x2,0	29,4 (3)	98,0 (10)
M314-04-015	10	60	45	15	8	M24x3,0	19,6 (2)	98,0 (10)
M314-04-016	10	60	45	15	8	M24x3,0	39,2 (4)	196,1 (20)
M314-04-017	15	70	45	20	12	M30x3,5	29,4 (3)	147,0 (15)
M314-04-018	15	70	45	20	12	M30x3,5	49,0 (5)	294,1 (30)

 Material :
 Steel

 Hardened
 HRC 36 ÷ 40

Black oxide finish.

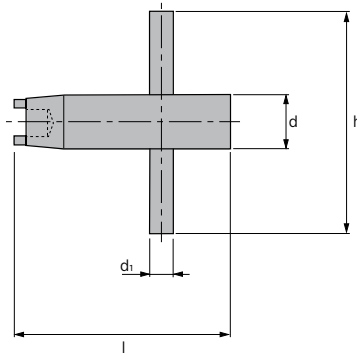

CODE	d	h	l	d ₁	Spring Plunger
M314-05-006	6	40	40	3	M5, M6
M314-05-008	8	45	45	4	M8
M314-05-010	10	45	45	4	M10
M314-05-012	12	50	50	5	M12
M314-05-016	16	70	52	8	M16
M314-05-024	24	80	62	12	M24
M314-05-030	30	100	73	15	M30



3

 Material :
 High grade alloy steel
 ISO 12.9

 Hardened
 HRC 39 ± 44

 Tensile Strength $R_m = 1200$
 N/mm²
 Yield Strength $R_p = 1080$ N/mm²
 Shear Strength $T_m = 720$ N/mm²
 Elongation A = %8 min.
 Impact Test : KCU 15J min.

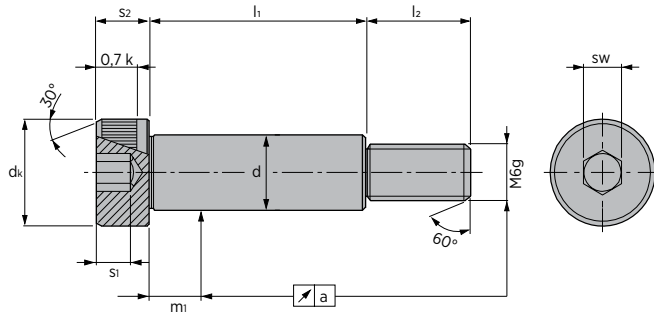
m1 measuring point = "d"



d h8	6	8	10	12	16	20	24
M	M5	M6	M8	M10	M12	M16	M20
dk / s2	10/ 4,5	13/ 5,5	16/ 7	18/ 9	24/ 11	30/ 14	36/ 16
l2 ±0,25	9,5	11	13	16	18	22	27
s1 / sw	2,4/3	3,3/4	4,2/5	4,9/6	6,6/8	8,8/10	10/12
l1 js11							
10	•						
12	•	•					
15	•	•	•	•			
16	•	•	•	•			
20	•	•	•	•			
25	•	•	•	•			
30	•	•	•	•	•		

d h8	6	8	10	12	16	20	24
l1 js11							
35	•	•	•	•	•		
40	•	•	•	•	•	•	
45	•	•	•	•	•	•	
50	•	•	•	•	•	•	•
55	•	•	•	•	•	•	•
60	•	•	•	•	•	•	•
65		•	•	•	•	•	•
70		•	•	•	•	•	•
80		•	•	•	•	•	•
90		•	•	•	•	•	•
100		•	•	•	•	•	•
120				•	•	•	•

Order Example:
 d= 6, l1= 10

Order Code:
 M315-01-0506010

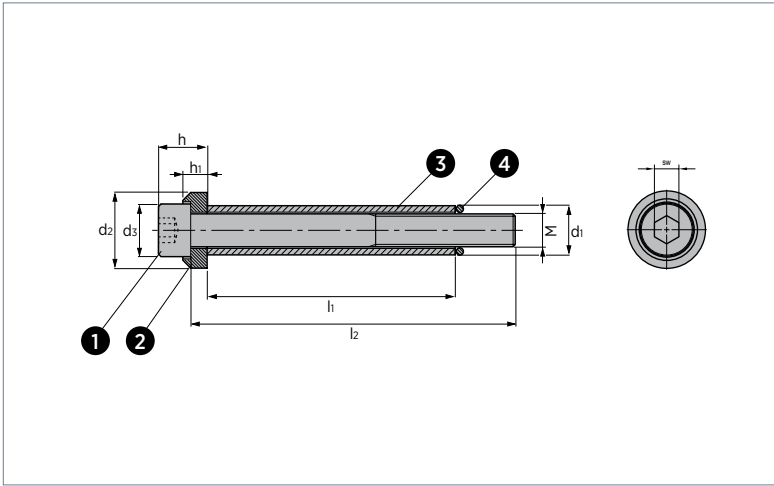

- 1 DIN 912 cl. 12.9
 - 2 Material: Steel 1000 N/mm²
 - 3 Material: Steel 1200 ÷ 1400 N/mm²
 - 4 O-Ring*
- * Remove before assembly



d₁ h₇	10	12,5	15	17,5	23
M	M6	M8	M10	M12	M16
d₂	15	19	23	27	34
d₃	10	13	16	18	24
h	10	13	15	18	24
h₁	5,5	6,5	7,5	9	11
sw	5	6	8	10	14
l₁ ±0,1	l₂				
20	35				
25	40				
30	45	45	50		
35	50	50	55		
40	55	55	60	60	
45	60	60	65	65	
50	65	65	70	70	80
55	70	70	75	80	
60	80	80	80	90	90
70	90	90	90	100	100
80	100	100	100	110	110
90	110	110	110	120	120
100	120	120	120	130	130
110				140	140
120			140	150	150
140				170	180
150					180
160					200

Order Example:
M= 6, l= 20

Order Code:
M315-02-06020

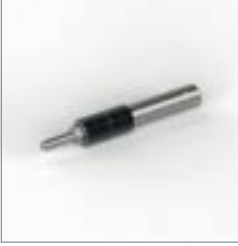
3

Material :
Pin 90Mn4

Hardened
HRC 36 ÷ 40

Body 34CrMo4

Black oxide finish.

Colour marking yellow.

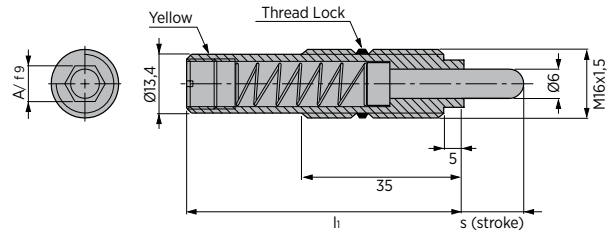

CODE	l_i	s	Spring Rate (N/mm)	Initial Force N	Final Force N
S504-03-010060	60	10	0,95	3,8	13,3
S504-03-015060	60	15	2	10	40
S504-03-020080	80	20	1,38	6,9	34,5
S504-03-030080	80	30	1,3	6,5	45,5
S504-03-030120	120	30	0,73	18	40
S504-03-040150	150	40	0,6	13,2	37,2
S504-03-050150	150	50	0,6	13,2	43,2
S504-03-060150	150	60	0,6	13,2	49,2
S504-03-070200	200	70	0,44	9,68	40,5
S504-03-080200	200	80	0,44	9,68	44,8



 Material :
 Pin 90Mn4

 Hardened
 HRC 36 ÷ 40

Body 34CrMo4

Black oxide finish.

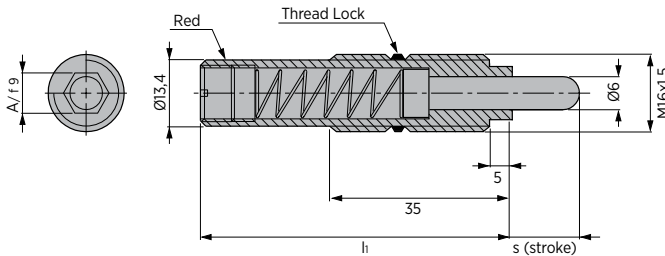
Colour marking red.



CODE	h	s	Spring Rate (N /mm)	Initial Force (N)	Final Force (N)
S504-04-010060	60	10	3,25	13	45,5
S504-04-015060	60	15	2,60	15	56,0
S504-04-020080	80	20	6,90	34,5	172,5
S504-04-030120	120	30	2	20	80,0
S504-04-030150	150	30	2,55	56,1	132,6
S504-04-040150	150	40	2,55	56,1	158,1
S504-04-050200	200	50	1,61	19,3	99,9
S504-04-060200	200	60	1,61	19,3	116,1
S504-04-070200	200	70	1,61	19,3	132,1
S504-04-080200	200	80	0,94	25	100,1

3

Material :
Pin 90Mn4

Hardened
HRC 36 ÷ 40

Body 34CrMo4

Black oxide finish.

Colour marking yellow.

***The spring pin made from high performance plastic with additives permits lateral loading of max. 15° depending on the stroke length.**

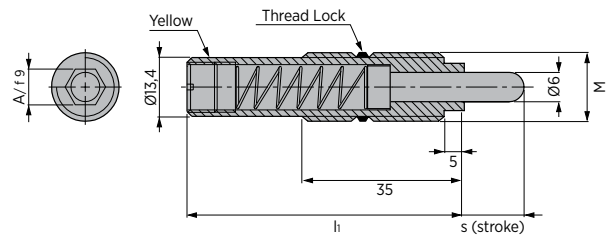

CODE	M	li	s	Spring Rate (N /mm)	Initial Force N	Final Force N
S504-05-010060	16x1,5	60	10	0,95	3,8	13,3
S504-05-010060-002	16x2	60	10	0,95	3,8	13,3
S504-05-015060	16x1,5	60	15	2	10	40
S504-05-015060-002	16x2	60	15	2	10	40
S504-05-020080	16x1,5	80	20	1,38	6,9	34,5
S504-05-020080-002	16x2	80	20	1,38	6,9	34,5
S504-05-030080	16x1,5	80	30	1,3	6,5	45,5
S504-05-030080-002	16x2	80	30	1,3	6,5	45,5
S504-05-030120	16x1,5	120	30	0,73	18	40
S504-05-030120-002	16x2	120	30	0,73	18	40
S504-05-040150	16x1,5	150	40	0,6	13,2	37,2
S504-05-040150-002	16x2	150	40	0,6	13,2	37,2
S504-05-050150	16x1,5	150	50	0,6	13,2	43,2
S504-05-050150-002	16x2	150	50	0,6	13,2	43,2

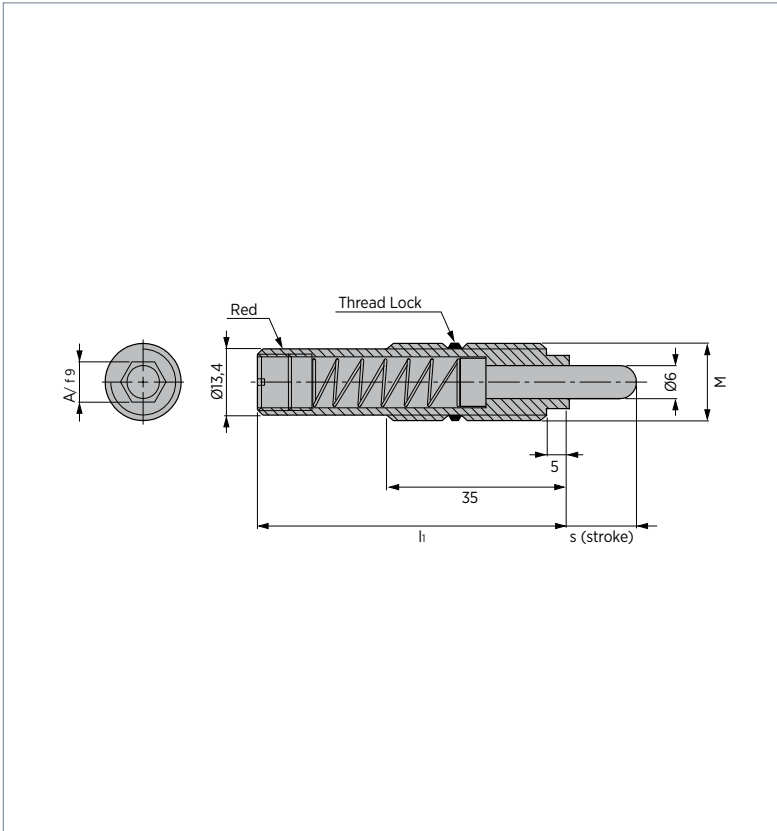
 Material :
 Pin 90Mn4

 Hardened
 HRC 36 ÷ 40

Body 34CrMo4

Black oxide finish.

Colour marking red.

***The spring pin made from high performance plastic with additives permits lateral loading of max. 15° depending on the stroke length.**

CODE	M	li	s	Spring Rate (N /mm)	Initial Force (N)	Final Force (N)
S504-06-010060	16x1,5	60	10	3,25	13	45,5
S504-06-010060-002	16x2	60	10	3,25	13	45,5
S504-06-015060	16x1,5	60	15	2,6	15	56
S504-06-015060-002	16x2	60	15	2,6	15	56
S504-06-020080	16x1,5	80	20	6,9	34,5	172,5
S504-06-020080-002	16x2	80	20	6,9	34,5	172,5
S504-06-030120	16x1,5	120	30	2	20	80
S504-06-030120-002	16x2	120	30	2	20	80
S504-06-030150	16x1,5	150	30	2,55	56,1	132,6
S504-06-030150-002	16x2	150	30	2,55	56,1	132,6
S504-06-040150	16x1,5	150	40	2,55	56,1	158,1
S504-06-040150-002	16x2	150	40	2,55	56,1	158,1
S504-06-050200	16x1,5	200	50	1,61	19,3	99,9
S504-06-050200-002	16x2	200	50	1,61	19,3	99,9

3

 Material :
 Pin 90Mn4

 Hardened
 HRC 36 ÷ 40

Body 34CrMo4

Black oxide finish.

Colour marking white.

***The spring pin made from high performance plastic with additives permits lateral loading of max. 15° depending on the stroke length.**

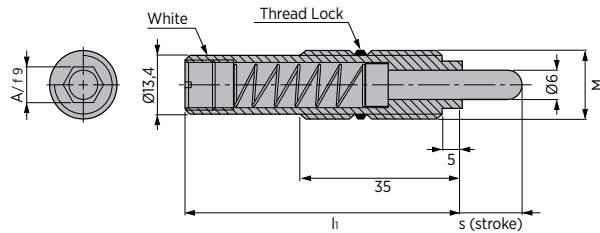

CODE	M	h _i	s	Spring Rate (N/mm)	Initial Force N	Final Force N
S504-07-020080	16x1,5	80	20	3,02	15,1	75,6
S504-07-020080-002	16x2	80	20	3,02	15,1	75,6

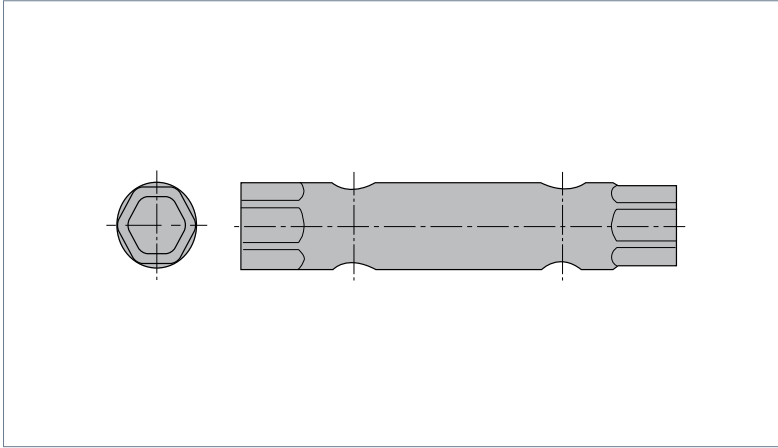
 Material :
 Steel

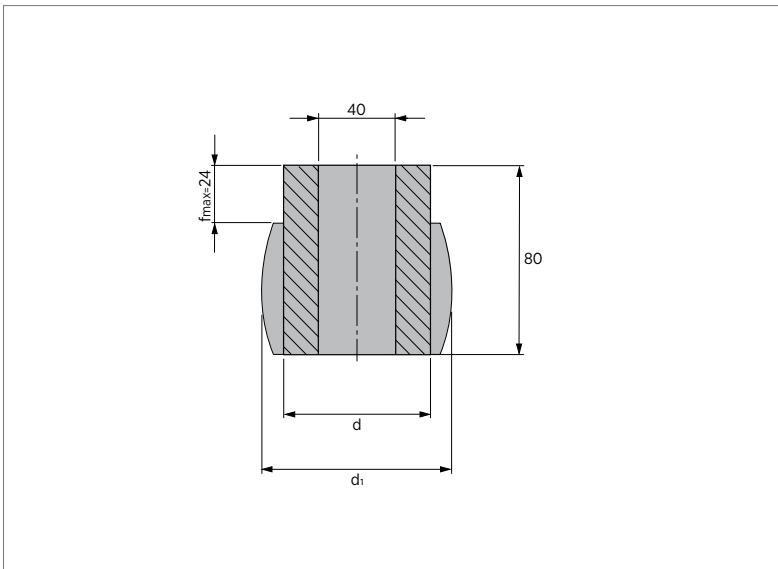
3
CODE
S504-08-016

 Material :
 Elastomer 92 Shore A

CODE	d	di
S510-05-003	80	106
S510-05-004	90	117

3

Material :
 Polyurethane - Ultraflex

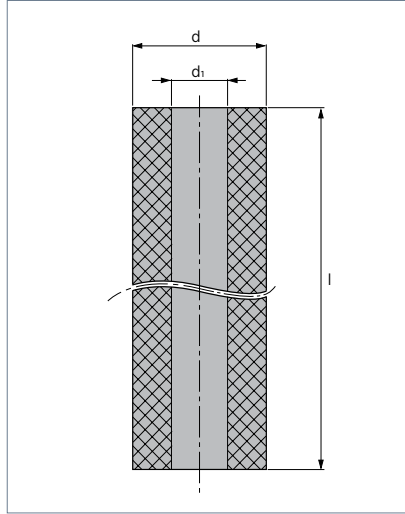
Hardness - Color - Deflection
 82 Shore A - Yellow %35
 92 Shore A - Red %30
 94 Shore A - Green %25



CODE	d	d ₁	l
S512-1XX-0160250	16	6,5	250
S512-1XX-0200250	20	8,5	250
S512-1XX-0250250	25	10,5	250
S512-1XX-0320500	32	13,5	500
S512-1XX-0400500	40	13,5	500
S512-1XX-0500500	50	17	500
S512-1XX-0630500	63	17	500
S512-1XX-0800500	80	21	500
S512-1XX-1000500	100	21	500
S512-1XX-1250500	125	27	500

Order Example:
 d= 32, l= 500, Hardness= 92 Sh

Order Code:
 S512-192-0320500



Material :
 Polyurethane - Ultraflex

Hardness - Color - Deflection
 82 Shore A - Yellow %35
 92 Shore A - Red %30
 94 Shore A - Green %25

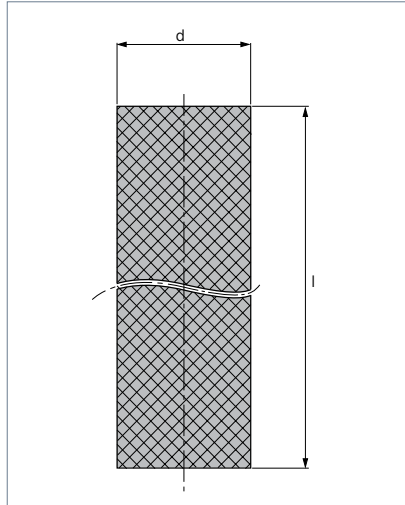

CODE	d	l
S513-1XX-0160250	16	250
S513-1XX-0200250	20	250
S513-1XX-0250250	25	250
S513-1XX-0320500	32	500
S513-1XX-0400500	40	500
S513-1XX-0500500	50	500
S513-1XX-0630500	63	500
S513-1XX-0800500	80	500
S513-1XX-1000500	100	500
S513-1XX-1250500	125	500

Order Example:
 d= 32, l= 500, Hardness= 92 Sh

Order Code:
 S513-192-0320500

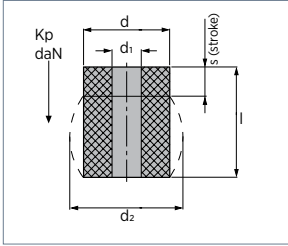

Material:
 Polyurethane - Ultraflex

Hardness - Colour - Deflection
 82 Shore A - Yellow %35
 92 Shore A - Red %30
 94 Shore A - Green %25

Order Example:
d= 32, l= 50, Hardness= 92 Sh

Order Code:
 S514-192-032050



				S514-182			S514-192			S514-194		
				Mak. Esneme %35 Ultrafleks 82 Shore Yellow			Mak. Esneme %30 Ultrafleks 92 Shore Red			Mak. Esneme %25 Ultrafleks 94 Shore Green		
dxl	d	d1	l	s	d2	Kp	s	d2	Kp	s	d2	Kp
mm	mm	mm	mm	mm	mm	daN	mm	mm	daN	mm	mm	daN
016 x 16	16	6,5	16	5,6	22	80	4,8	19	130	4	19	160
016 x 20	16	6,5	20	7	22	80	6	19	130	5	19	160
016 x 25	16	6,5	25	9	22	80	7,5	19	130	6	19	160
016 x 32	16	6,5	32	11,2	22	80	9,6	19	130	8	19	160
020 x 16	20	8,5	16	6	28	150	4,8	26	200	4	25	325
020 x 20	20	8,5	20	7	28	150	6	26	200	5	25	325
020 x 25	20	8,5	25	9	28	150	7,5	26	200	6	25	325
020 x 32	20	8,5	32	11,2	28	150	9,6	26	200	8	25	325
020 x 40	20	8,5	40	14	28	150	12	26	200	10	25	325
025 x 16	25	10,5	16	6	33	210	4,8	30	300	4	29	450
025 x 20	25	10,5	20	7	33	210	6	30	300	5	29	450
025 x 25	25	10,5	25	9	33	210	7,5	30	300	6	29	450
025 x 32	25	10,5	32	11	33	210	9,6	30	300	8	29	450
025 x 40	25	10,5	40	14	33	210	12	30	300	10	29	450
025 x 50	25	10,5	50	17,5	33	210	15	30	300	13	29	450
032 x 16	32	13,5	16	6	43	360	4,8	41	580	4	38	800
032 x 20	32	13,5	20	7	43	360	6	41	580	5	38	800
032 x 25	32	13,5	25	9	43	360	7,5	41	580	6	38	800
032 x 32	32	13,5	32	11	43	360	9,6	41	580	8	38	800
032 x 40	32	13,5	40	14	43	360	12	41	580	10	38	800
032 x 50	32	13,5	50	18	43	360	15	41	580	13	38	800
032 x 63	32	13,5	63	22	43	360	19	41	580	16	38	800
040 x 20	40	13,5	20	7	54	650	6	50	1250	5	47	1500
040 x 25	40	13,5	25	9	54	650	7,5	50	1250	6	47	1500
040 x 32	40	13,5	32	11	54	650	9,6	50	1250	8	47	1500
040 x 40	40	13,5	40	14	54	650	12	50	1250	10	47	1500
040 x 50	40	13,5	50	18	54	650	15	50	1250	13	47	1500
040 x 63	40	13,5	63	22	54	650	19	50	1250	16	47	1500
040 x 80	40	13,5	80	28	54	650	24	50	1250	20	47	1500
050 x 25	50	17	25	9	65	1100	7,5	62	1700	6	60	2000
050 x 32	50	17	32	11	65	1100	9,6	62	1700	8	60	2000
050 x 40	50	17	40	14	65	1100	12	62	1700	10	60	2000
050 x 50	50	17	50	18	65	1100	15	62	1700	13	60	2000
050 x 63	50	17	63	22	65	1100	19	62	1700	16	60	2000
050 x 80	50	17	80	28	65	1100	24	62	1700	20	60	2000
050 x 100	50	17	100	35	65	1100	30	62	1700	25	60	2000



Order Example:
d= 80, l= 100, Hardness= 92 Sh

Order Code:
 S514-192-080100

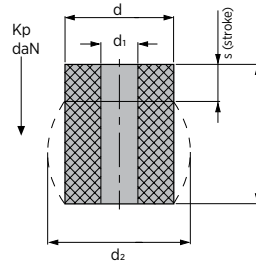
3

Material:
 Polyurethane - Ultraflex

Hardness - Colour - Deflection

82 Shore A - Yellow	%35
92 Shore A - Red	%30
94 Shore A - Green	%25

				S514-182			S514-192			S514-194		
				Mak. Esneme %35 Ultrafleks 82 Shore Yellow			Mak. Esneme %30 Ultrafleks 92 Shore Red			Mak. Esneme %25 Ultrafleks 94 Shore Green		
dxl	d	d1	l	s	d2	Kp	s	d2	Kp	s	d2	Kp
mm	mm	mm	mm	mm	mm	daN	mm	mm	daN	mm	mm	daN
063 x 32	63	17	32	11	81	1600	9,6	78	2600	8	74	3500
063 x 40	63	17	40	14	81	1600	12	78	2600	10	74	3500
063 x 50	63	17	50	18	81	1600	15	78	2600	13	74	3500
063 x 63	63	17	63	22	81	1600	19	78	2600	16	74	3500
063 x 80	63	17	80	28	81	1600	24	78	2600	20	74	3500
063 x 100	63	17	100	35	81	1600	30	78	2600	25	74	3500
063 x 125	63	17	125	44	81	1600	37,5	78	2600	31	74	3500
080 x 40	80	21	40	14	103	2600	12	98	4300	10	95	6000
080 x 50	80	21	50	18	103	2600	15	98	4300	13	95	6000
080 x 63	80	21	63	22	103	2600	19	98	4300	16	95	6000
080 x 80	80	21	80	28	103	2600	24	98	4300	20	95	6000
080 x 100	80	21	100	35	103	2600	30	98	4300	25	95	6000
080 x 125	80	21	125	44	103	2600	37,5	98	4300	31	95	6000
080 x 160	80	21	160	56	103	2600	48	98	4300	40	95	6000
0100 x 50	100	21	50	18	126	4300	15	120	5900	13	120	10000
0100 x 63	100	21	63	22	126	4300	19	120	5900	16	120	10000
0100 x 80	100	21	80	28	126	4300	24	120	5900	20	120	10000
0100 x 100	100	21	100	35	126	4300	30	120	5900	25	120	10000
0100 x 125	100	21	125	44	126	4300	37,5	120	5900	31	120	10000
0100 x 160	100	21	160	56	126	4300	48	120	5900	40	120	10000
0125 x 63	125	27	63	22	160	6400	19	152	9900	15,7	150	15000
0125 x 80	125	27	80	28	160	6400	24	152	9900	20	150	15000
0125 x 100	125	27	100	35	160	6400	30	152	9900	25	150	15000
0125 x 125	125	27	125	43,7	160	6400	37,5	152	9900	31,2	150	15000
0125 x 160	125	27	160	56	160	6400	48	152	9900	40	150	15000
0125 x 200	125	27	200	70	160	6400	60	152	9900	50	150	15000

CODE	Colour	Lt.
D901-01-745	Blue	250 ml.



Physical and Chemical Properties	
Physical State	Paste
Colour	Blue
Odour	Characteristic
Melting Point	45 °C
Flammability	> 150 °C
Explosiveness	not explosive
Density	0,85 g /ml
Solubity	In many solvents
Water Solubility (20°C)	Insoluble

Fiziksel ve Kimyasal Özellikler	
Fiziksel Durum	Paste
Renk	Mavi
Koku	Karakteristik
Erime Noktası	45 °C
Yanma Derecesi	> 150 °C
Patlayıcılık	Patlayıcı özelliği yoktur.
Yoğunluk	0,85 g /ml
Çözünürlük	Birçok çözücü de çözünür.
Suda Çözünme (20°C)	Suda çözünmez

Physikalische und chemische Eigenschaften	
Physischer Zustand	Paste
Farbe	Blau
Geruch	Karakteristik
Schmelzpunkt	45 °C
Endzündbarkeit	> 150 °C
Brisant	Keine
Dichte	0,85 g /ml
Lösbarkeit	Mit den meisten Lösungsmittel lösbar
Wasserlöslichkeit (20°C)	Keine

